 **adafruit learning system**

## **I2C addresses!**

Created by lady ada



Last updated on 2018-01-12 05:51:13 PM UTC

# Guide Contents

Guide Contents	2
Overview	5
I2C - Inter-Integrated Circuit communications!	5
The List	7
Special cases:	7
0x00 - 0x0F	7
0x00 - Reserved - General Call Address	7
0x01 - Reserved for CBUS Compatibility	7
0x02 - Reserved for I2C-compatible Bus Variants	7
0x03 - Reserved for Future Use	7
0x04, 0x05, 0x06, 0x07 - Reserved for Hs-mode Master	7
0x0E	7
0x10 - 0x1F	7
0x11	7
0x13	7
0x18	7
0x19	7
0x1A	7
0x1B	7
0x1C	8
0x1D	8
0x1E	8
0x1F	8
0x20-0x2F	8
0x20	8
0x21	8
0x22	8
0x23	8
0x24	8
0x25	9
0x26	9
0x27	9
0x28	9
0x29	9
0x2A	9
0x2B	9
0x2C	9
0x2D	9
0x30 - 0x3F	9
0x34	9
0x38	9
0x39	9
0x3C	10
0x3D	10
0x40 - 0x4F	10
0x40	10
0x41	10

0x42	10
0x43	10
0x44	10
0x45	10
0x46	11
0x47	11
0x48	11
0x49	11
0x4A	11
0x4B	11
0x4C	11
0x4D	11
0x4E	11
0x4F	11
<b>0x50 - 0x5F</b>	<b>11</b>
0x50	12
0x51	12
0x52	12
0x53	12
0x54	12
0x55	12
0x56	12
0x57	12
0x58	12
0x5A	12
0x5B	12
0x5C	12
0x5D	12
<b>0x60 - 0x6F</b>	<b>12</b>
0x60	13
0x61	13
0x62	13
0x63	13
0x64	13
0x65	13
0x66	13
0x67	13
0x68	13
0x69	13
0x6A	13
0x6B	14
<b>0x70 - 0x7F</b>	<b>14</b>
0x70	14
0x71	14
0x72	14
0x73	14
0x74	14
0x75	14
0x76	14
0x77	14

0x78 0x79 0x7A 0x7B - Reserved for 10-bit I2C Addressing	15
0x7C 0x7D 0x7E 0x7F - Reserved for Future Purposes	15

## Overview

When people need to communicate with each other, we use language. If two people speak the same language, they can talk all they want about all sorts of topics. If they don't speak the same language, communication is difficult. Likewise, electronic parts need to communicate - and they also have their own languages. There are a few common languages that are spoken. The most popular ones are TTL Serial, SPI, I2C, I2S, 1-Wire, and Parallel (such as 8080 or 6800). Of these, Parallel and SPI can 'share a bus' using a select line - multiple devices can share the pins as long as they have a single pin that can be used to indicate who is permitted to speak at one time. 1-Wire and I2C are true shared-bus protocols - you can have 100+ components all talking at once using the same 2 wires (for I2C) or 1-wire (for the aptly-named 1-wire). 1-Wire is much slower than I2C and is a strongly-patented protocol owned by Maxim so you won't see a lot of devices out there other than Maxim/Dallas parts that use 1-wire.

## I2C - Inter-Integrated Circuit communications!

This guide doesn't cover the nitty-gritty details of I2C, other than to note that you can connect *multiple* I2C devices (often referred to as "I2C slaves") to a single I2C controller (a.k.a "I2C master") using only two wires.

For example, in this diagram, one Metro (e.g. Arduino compatible) connects to 5 devices.

In general, you can only have one controller and up to 127 devices. (There are exceptions such as multi-master and 10-bit address devices but they are so rare and we've never seen them in practice)

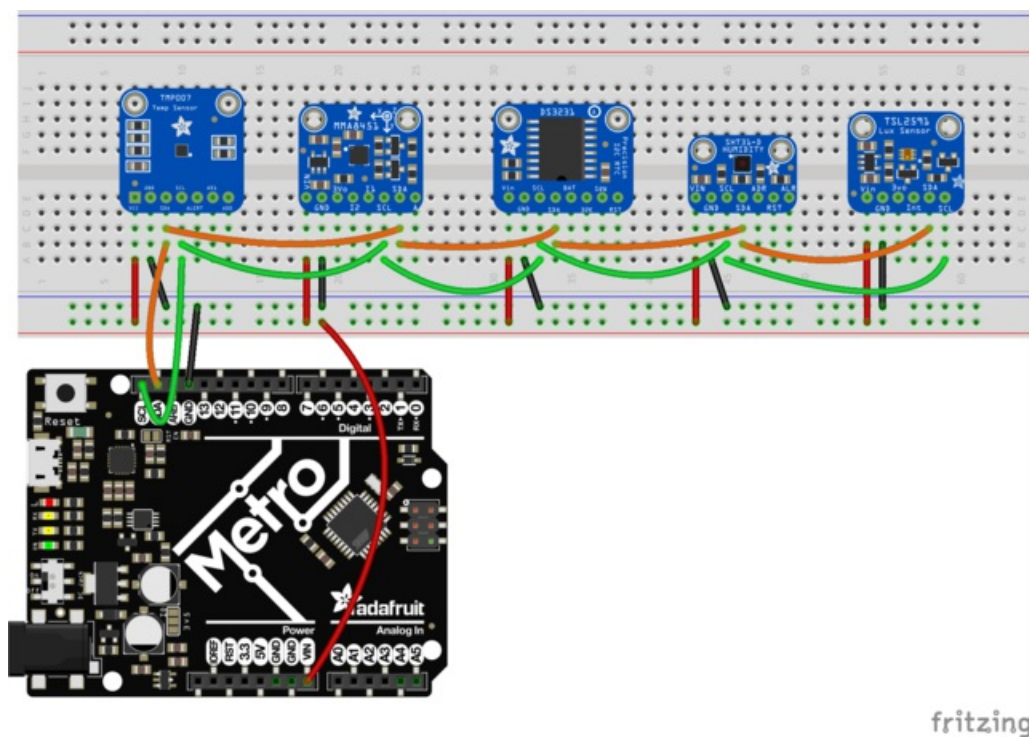

I2C demo fritzing file

<https://adafru.it/y6a>

I2C is incredibly popular because it uses only 2 wires, and like we said, multiple devices can share those wires, making it a great way to connect tons of sensors, drivers, expanders, without using all the microcontroller pins. The only bad news about I2C is that **each I2C device must have a unique address** - and the addresses only range from 0 to 127 (aka 0 to 0x7F hex). One thing this means is that if you have two accelerometers (lets say) and they both have address 0x22

you cannot have both of them on the same I2C lines.

There are a few work-arounds:

- One is you might be able to power down or 'de-select' one sensor or another at a time.
- Another is that some boards have an address-select line or jumper or other configuration. If you can set one to a different address you're good to go.
- Some devices have a software-reprogrammable address, where they come up as one address on boot but can be told to change address. Oftentimes, the new address is forgotten on reboots, so you have to de-power all the other similarly-addressed devices while you do so.
- [You can use an I2C multiplexer like the TCA9548A](#) which will let you use one I2C address to talk to the multiplexer and tell it which line you want to enable

Since we deal with so many I2C devices we thought it would be handy to have a table with all the most common sensors and modules we encounter, and their I2C address!

Continue onto the next page to see our current list

## The List

OMG Can you believe it? We didn't include every I2C device in the known universe! Fear not, if you post up in the Adafruit forums with your favorite I2C device and the 7-bit addresses they use, we'll update this list! (eventually)

All I2C addresses here are in 7-bit format

### Special cases:

---

- [PCA9685](#) can be used by any address between 0x40 to 0x7F
- 0x00 - 0x07 and 0x78 - 0x7F are reserved I2C addresses

### 0x00 - 0x0F

---

0x00 - Reserved - General Call Address

0x01 - Reserved for CBUS Compatibility

0x02 - Reserved for I2C-compatible Bus Variants

0x03 - Reserved for Future Use

0x04, 0x05, 0x06, 0x07 - Reserved for Hs-mode Master

0x0E

- [MAG3110 3-Axis Magnetometer](#) (0x0E only)

### 0x10 - 0x1F

---

0x11

- [Si4713 FM Transmitter with RDS](#) (0x11 or 0x63)

0x13

- [VCNL40x0 proximity sensor](#) (0x13 only)

0x18

- [MCP9808 temp sensor](#) (0x18 - 0x1F)
- [LIS3DH 3-axis accelerometer](#) (0x18 or 0x19)
- [LSM303 Accelerometer & Magnetometer](#) (0x19 for accelerometer and 0x1E for magnetometer)

0x19

- [MCP9808 temp sensor](#) (0x18 - 0x1F)
- [LIS3DH 3-axis accelerometer](#) (0x18 or 0x19)

0x1A

- [MCP9808 temp sensor](#) (0x18 - 0x1F)

0x1B

- [MCP9808 temp sensor](#) (0x18 - 0x1F)

## 0x1C

- [MCP9808 temp sensor](#) (0x18 - 0x1F)
- [MMA845x 3-axis Accelerometer](#) (0x1C or 0x1D)
- [FXOS8700 Accelerometer/Magnetometer](#) (0x1C, 0x1D, 0x1E or 0x1F)
- [MMA7455L](#) (0x1C or 0x1D)

## 0x1D

- [MCP9808 temp sensor](#) (0x18 - 0x1F)
- [MMA845x 3-axis Accelerometer](#) (0x1C or 0x1D)
- [FXOS8700 Accelerometer/Magnetometer](#) (0x1C, 0x1D, 0x1E or 0x1F)
- [LSM9DS0 9-axis IMU](#) (0x1D or 0x1E for Accel/Mag, 0x6A or 0x6B for Gyro)
- [ADXL345 3-axis accelerometer](#) (0x1D or 0x53)
- [MMA7455L](#) (0x1C or 0x1D)

## 0x1E

- [MCP9808 temp sensor](#) (0x18 - 0x1F)
- [FXOS8700 Accelerometer/Magnetometer](#) (0x1C, 0x1D, 0x1E or 0x1F)
- [LSM303 Accelerometer & Magnetometer](#) (0x19 for accelerometer and 0x1E for magnetometer)
- [LSM9DS0 9-axis IMU](#) (0x1D or 0x1E for Accel/Mag, 0x6A or 0x6B for Gyro)
- [HMC5883 Magnetometer](#) (0x1E only)

## 0x1F

- [MCP9808 temp sensor](#) (0x18 - 0x1F)
- [FXOS8700 Accelerometer/Magnetometer](#) (0x1C, 0x1D, 0x1E or 0x1F)

## 0x20-0x2F

---

### 0x20

- [FXAS21002 Gyroscope](#) (0x20 or 0x21)
- [Chirp! Water sensor](#) (0x20)
- [MCP23008 I2C GPIO expander](#) (0x20 - 0x27)
- [MCP23017 I2C GPIO expander](#) (0x20 - 0x27)

### 0x21

- [FXAS21002 Gyroscope](#) (0x20 or 0x21)
- [MCP23008 I2C GPIO expander](#) (0x20 - 0x27)
- [MCP23017 I2C GPIO expander](#) (0x20 - 0x27)

### 0x22

- [MCP23008 I2C GPIO expander](#) (0x20 - 0x27)
- [MCP23017 I2C GPIO expander](#) (0x20 - 0x27)

### 0x23

- [MCP23008 I2C GPIO expander](#) (0x20 - 0x27)
- [MCP23017 I2C GPIO expander](#) (0x20 - 0x27)

### 0x24

- [MCP23008 I2C GPIO expander](#) (0x20 - 0x27)



- [MCP23017 I2C GPIO expander](#) (0x20 - 0x27)

## 0x25

- [MCP23008 I2C GPIO expander](#) (0x20 - 0x27)
- [MCP23017 I2C GPIO expander](#) (0x20 - 0x27)

## 0x26

- [MCP23008 I2C GPIO expander](#) (0x20 - 0x27)
- [MCP23017 I2C GPIO expander](#) (0x20 - 0x27)

## 0x27

- [MCP23008 I2C GPIO expander](#) (0x20 - 0x27)
- [MCP23017 I2C GPIO expander](#) (0x20 - 0x27)

## 0x28

- [BNO055 IMU](#) (0x28 or 0x29)
- [CAP1188 8-channel Capacitive Touch](#) (0x28 - 0x2D )

## 0x29

- [BNO055 IMU](#) (0x28 or 0x29)
- [TCS34725 color sensor](#) (0x29 only)
- [TSL2561 light sensor](#) (0x29, 0x39 or 0x49)
- [TSL2591 light sensor](#) (0x29 only)
- [VL53L0x ToF distance](#) (0x29, software selectable)
- [VL6180X ToF sensor](#) (0x29)
- [CAP1188 8-channel Capacitive Touch](#) (0x28 - 0x2D )

## 0x2A

- [CAP1188 8-channel Capacitive Touch](#) (0x28 - 0x2D )

## 0x2B

- [CAP1188 8-channel Capacitive Touch](#) (0x28 - 0x2D )

## 0x2C

- [CAP1188 8-channel Capacitive Touch](#) (0x28 - 0x2D )

## 0x2D

- [CAP1188 8-channel Capacitive Touch](#) (0x28 - 0x2D )

## 0x30 - 0x3F

---

## 0x34

## 0x38

- [VEML6070 UV Index](#) (0x38 and 0x39)
- [FT6x06 Capacitive Touch Driver](#) (0x38 only)

## 0x39

- [TSL2561 light sensor](#) (0x29, 0x39 or 0x49)
- [VEML6070 UV Index](#) (0x38 and 0x39)

- [APDS-9960 IR/Color/Proximity Sensor \(0x39 only\)](#)

## 0x3C

- [SSD1305 monochrome OLED \(0x3C or 0x3D, hardware selectable on some displays with a solder connection\)](#)
- [SSD1306 monochrome OLED \(0x3C or 0x3D, hardware selectable on some displays with a solder connection\)](#)

## 0x3D

- [SSD1305 monochrome OLED \(0x3C or 0x3D, hardware selectable on some displays with a solder connection\)](#)
- [SSD1306 monochrome OLED \(0x3C or 0x3D, hardware selectable on some displays with a solder connection\)](#)

## 0x40 - 0x4F

---

### 0x40

- [Si7021 Humidity/Temp sensor \(0x40 only\)](#)
- [HTU21D-F Humidity/Temp Sensor \(0x40 only\)](#)
- [HDC1008 Humidity/Temp sensor \(0x40, 0x41, 0x42 or 0x43\)](#)
- [TMP007 IR Temperature sensor \(0x40 - 0x47\)](#)
- [TMP006 IR Temperature sensor \(0x40 - 0x47\)](#)
- [PCA9685 16-channel PWM driver default address \(0x40 - 0x7F\)](#)
- [INA219 High-Side DC Current/Voltage sensor \(0x40 - 0x4F\)](#)

### 0x41

- [HDC1008 Humidity/Temp sensor \(0x40, 0x41, 0x42 or 0x43\)](#)
- [TMP007 IR Temperature sensor \(0x40 - 0x47\)](#)
- [TMP006 IR Temperature sensor \(0x40 - 0x47\)](#)
- [INA219 High-Side DC Current/Voltage sensor \(0x40 - 0x4F\)](#)
- [STMPE610/STMPE811 Resistive Touch controller \(0x41 or 0x44\)](#)

### 0x42

- [HDC1008 Humidity/Temp sensor \(0x40, 0x41, 0x42 or 0x43\)](#)
- [TMP007 IR Temperature sensor \(0x40 - 0x47\)](#)
- [TMP006 IR Temperature sensor \(0x40 - 0x47\)](#)
- [INA219 High-Side DC Current/Voltage sensor \(0x40 - 0x4F\)](#)

### 0x43

- [HDC1008 Humidity/Temp sensor \(0x40, 0x41, 0x42 or 0x43\)](#)
- [TMP007 IR Temperature sensor \(0x40 - 0x47\)](#)
- [TMP006 IR Temperature sensor \(0x40 - 0x47\)](#)
- [INA219 High-Side DC Current/Voltage sensor \(0x40 - 0x4F\)](#)

### 0x44

- [SHT31 Humidity/Temp sensor \(0x44 or 0x45 selectable\)](#)
- [TMP007 IR Temperature sensor \(0x40 - 0x47\)](#)
- [TMP006 IR Temperature sensor \(0x40 - 0x47\)](#)
- [ISL29125 Color Sensor \(0x44 only\)](#)
- [INA219 High-Side DC Current/Voltage sensor \(0x40 - 0x4F\)](#)
- [STMPE610/STMPE811 Resistive Touch controller \(0x41 or 0x44\)](#)

### 0x45

- [SHT31 Humidity/Temp sensor \(0x44 or 0x45 selectable\)](#)

- [TMP007 IR Temperature sensor](#) (0x40 - 0x47)
- [TMP006 IR Temperature sensor](#) (0x40 - 0x47)
- [INA219 High-Side DC Current/Voltage sensor](#) (0x40 - 0x4F)

## 0x46

- [TMP007 IR Temperature sensor](#) (0x40 - 0x47)
- [TMP006 IR Temperature sensor](#) (0x40 - 0x47)
- [INA219 High-Side DC Current/Voltage sensor](#) (0x40 - 0x4F)

## 0x47

- [TMP007 IR Temperature sensor](#) (0x40 - 0x47)
- [TMP006 IR Temperature sensor](#) (0x40 - 0x47)
- [INA219 High-Side DC Current/Voltage sensor](#) (0x40 - 0x4F)

## 0x48

- [TMP102 Temperature sensor](#) (0x48 0x49 0x4A or 0x4B)
- [PN532 NFC/RFID reader](#) (0x48 only)
- [ADS1115 4-channel 16-bit ADC](#) (0x48 0x49 0x4A or 0x4B)
- [INA219 High-Side DC Current/Voltage sensor](#) (0x40 - 0x4F)

## 0x49

- [TSL2561 light sensor](#) (0x29, 0x39 or 0x49)
- [TMP102 Temperature sensor](#) (0x48 0x49 0x4A or 0x4B)
- [ADS1115 4-channel 16-bit ADC](#) (0x48 0x49 0x4A or 0x4B)
- [INA219 High-Side DC Current/Voltage sensor](#) (0x40 - 0x4F)

## 0x4A

- [TMP102 Temperature sensor](#) (0x48 0x49 0x4A or 0x4B)
- [ADS1115 4-channel 16-bit ADC](#) (0x48 0x49 0x4A or 0x4B)
- [INA219 High-Side DC Current/Voltage sensor](#) (0x40 - 0x4F)

## 0x4B

- [TMP102 Temperature sensor](#) (0x48 0x49 0x4A or 0x4B)
- [ADS1115 4-channel 16-bit ADC](#) (0x48 0x49 0x4A or 0x4B)
- [INA219 High-Side DC Current/Voltage sensor](#) (0x40 - 0x4F)

## 0x4C

- [INA219 High-Side DC Current/Voltage sensor](#) (0x40 - 0x4F)

## 0x4D

- [INA219 High-Side DC Current/Voltage sensor](#) (0x40 - 0x4F)

## 0x4E

- [INA219 High-Side DC Current/Voltage sensor](#) (0x40 - 0x4F)

## 0x4F

- [INA219 High-Side DC Current/Voltage sensor](#) (0x40 - 0x4F)

## 0x50 - 0x5F

---

## 0x50

- [MB85RC I2C FRAM](#) (0x50 - 0x57)

## 0x51

- [MB85RC I2C FRAM](#) (0x50 - 0x57)

## 0x52

- [MB85RC I2C FRAM](#) (0x50 - 0x57)
- [Nintendo Nunchuck controller](#) (0x52 only)

## 0x53

- [ADXL345 3-axis accelerometer](#) (0x1D or 0x53)
- [MB85RC I2C FRAM](#) (0x50 - 0x57)

## 0x54

- [MB85RC I2C FRAM](#) (0x50 - 0x57)

## 0x55

- [MB85RC I2C FRAM](#) (0x50 - 0x57)

## 0x56

- [MB85RC I2C FRAM](#) (0x50 - 0x57)

## 0x57

- [MB85RC I2C FRAM](#) (0x50 - 0x57)
- [MAX3010x Pulse & Oximetry sensor](#) (0x57)

## 0x58

- [TPA2016 I2C-controlled Amplifier](#) (0x58 only)
- [SGP30 Gas Sensor](#) (0x58 only)

## 0x5A

- [MPR121 12-point capacitive touch sensor](#) (0x5A, 0x5B, 0x5C, 0x5D)
- [CCS811 VOC sensor](#) (0x5A or 0x5B)
- [MLX9061x IR temperature sensor](#) (0x5A only)
- [DRV2605 Haptic Motor Driver](#) (0x5A only)

## 0x5B

- [MPR121 12-point capacitive touch sensor](#) (0x5A, 0x5B, 0x5C, 0x5D)
- [CCS811 VOC sensor](#) (0x5A or 0x5B)

## 0x5C

- [AM2315 Humidity/Temp sensor](#) (0x5C only)
- [MPR121 12-point capacitive touch sensor](#) (0x5A, 0x5B, 0x5C, 0x5D)

## 0x5D

- [MPR121 12-point capacitive touch sensor](#) (0x5A, 0x5B, 0x5C, 0x5D)

## 0x60 - 0x6F

---

## 0x60

- [MPL115A2 Barometric Pressure \(0x60 only\)](#)
- [MPL3115A2 Barometric Pressure \(0x60 only\)](#)
- [Si5351A Clock Generator \(0x60 or 0x61\)](#)
- [Si1145 Light/IR Sensor \(0x60 only\)](#)
- [MCP4725A0 12-bit DAC \(0x60 or 0x61\)](#)
- [TEA5767 Radio receiver \(0x60 only\)](#)

## 0x61

- [Si5351A Clock Generator \(0x60 or 0x61\)](#)
- [MCP4725A0 12-bit DAC \(0x60 or 0x61\)](#)

## 0x62

- [MCP4725A1 12-bit DAC \(0x62 or 0x63\)](#)

## 0x63

- [MCP4725A1 12-bit DAC \(0x62 or 0x63\)](#)
- [Si4713 FM Transmitter with RDS \(0x11 or 0x63\)](#)

## 0x64

- [MCP4725A2 12-bit DAC \(0x64 or 0x65\)](#)

## 0x65

- [MCP4725A2 12-bit DAC \(0x64 or 0x65\)](#)

## 0x66

- [MCP4725A3 12-bit DAC \(0x66 or 0x67\)](#)

## 0x67

- [MCP4725A3 12-bit DAC \(0x66 or 0x67\)](#)

## 0x68

This address is really popular with real time clocks, almost all of them use 0x68!

- [AMG8833 IR Thermal Camera Breakout \(0x68 or 0x69\)](#)
- [DS1307 RTC \(0x68 only\)](#)
- [PCF8523 RTC \(0x68 only\)](#)
- [DS3231 RTC \(0x68 only\)](#)
- [MPU-9250 9-DoF IMU \(0x68 or 0x69\)](#)
- [MPU-60X0 Accel+Gyro \(0x68 or 0x69\)](#)
- [ITG3200 Gyro \(0x68 or 0x69\)](#)

## 0x69

- [AMG8833 IR Thermal Camera Breakout \(0x68 or 0x69\)](#)
- [MPU-9250 \(0x68 or 0x69\)](#)
- [MPU-60X0 Accel+Gyro \(0x68 or 0x69\)](#)
- [ITG3200 Gyro \(0x68 or 0x69\)](#)

## 0x6A

- [L3GD20H gyroscope](#) (0x6A or 0x6B)
- [LSM9DS0 9-axis IMU](#) (0x1D or 0x1E for Accel/Mag, 0x6A or 0x6B for Gyro)

## 0x6B

- [L3GD20H gyroscope](#) (0x6A or 0x6B)
- [LSM9DS0 9-axis IMU](#) (0x1D or 0x1E for Accel/Mag, 0x6A or 0x6B for Gyro)

## 0x70 - 0x7F

---

### 0x70

- [TCA9548 1-to-8 I2C Multiplexer](#) (0x70 - 0x77)
- [HT16K33 LED Matrix Driver](#) (0x70 - 0x77)

### 0x71

- [TCA9548 1-to-8 I2C Multiplexer](#) (0x70 - 0x77)
- [HT16K33 LED Matrix Driver](#) (0x70 - 0x77)

### 0x72

- [TCA9548 1-to-8 I2C Multiplexer](#) (0x70 - 0x77)
- [HT16K33 LED Matrix Driver](#) (0x70 - 0x77)

### 0x73

- [TCA9548 1-to-8 I2C Multiplexer](#) (0x70 - 0x77)
- [HT16K33 LED Matrix Driver](#) (0x70 - 0x77)

### 0x74

- [IS31FL3731 144-LED CharliePlex driver](#) (0x74 0x75 0x66 or 0x77)
- [TCA9548 1-to-8 I2C Multiplexer](#) (0x70 - 0x77)
- [HT16K33 LED Matrix Driver](#) (0x70 - 0x77)

### 0x75

- [IS31FL3731 144-LED CharliePlex driver](#) (0x74 0x75 0x66 or 0x77)
- [TCA9548 1-to-8 I2C Multiplexer](#) (0x70 - 0x77)
- [HT16K33 LED Matrix Driver](#) (0x70 - 0x77)

### 0x76

- [BME280 Temp/Barometric/Humidity](#) (0x76 or 0x77)
- [BMP280 Temp/Barometric](#) (0x76 or 0x77)
- [IS31FL3731 144-LED CharliePlex driver](#) (0x74 0x75 0x66 or 0x77)
- [TCA9548 1-to-8 I2C Multiplexer](#) (0x70 - 0x77)
- [HT16K33 LED Matrix Driver](#) (0x70 - 0x77)
- [MS5607/MS5611 Barometric Pressure](#) (0x76 or 0x77)

### 0x77

- [BME280 Temp/Barometric/Humidity](#) (0x76 or 0x77)
- [BMP280 Temp/Barometric](#) (0x76 or 0x77)
- [BMP180 Temp/Barometric](#) (0x77 only)
- [BMP085 Temp/Barometric](#) (0x77 only)
- [TCA9548 1-to-8 I2C Multiplexer](#) (0x70 - 0x77)
- [IS31FL3731 144-LED CharliePlex driver](#) (0x74 0x75 0x66 or 0x77)

- [HT16K33 LED Matrix Driver](#) (0x70 - 0x77)
- BMA180 Accelerometer (0x77 only)
- MS5607/MS5611 Barometric Pressure (0x76 or 0x77)

0x78 0x79 0x7A 0x7B - Reserved for 10-bit I2C Addressing

0x7C 0x7D 0x7E 0x7F - Reserved for Future Purposes