

Guardian Robot with LEDs

Created by Ruiz Brothers

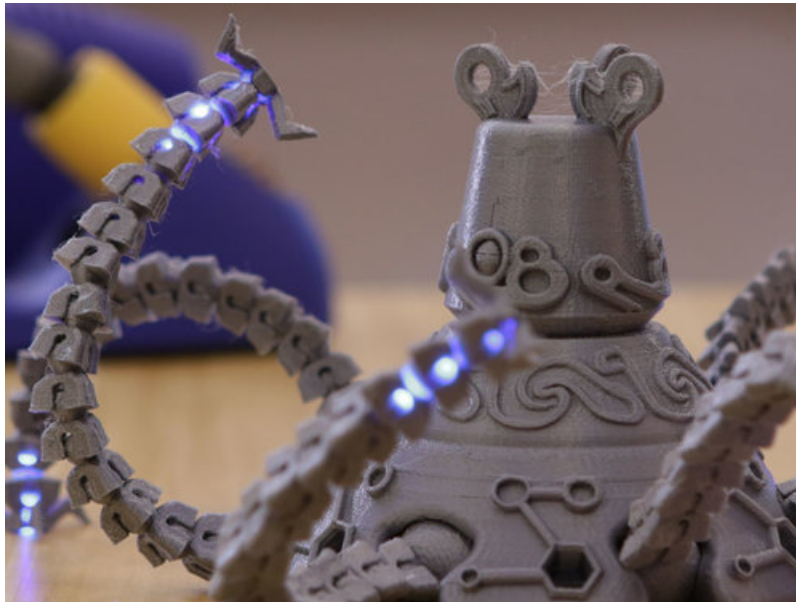

Last updated on 2018-08-22 04:01:08 PM UTC

Guide Contents

Guide Contents	2
Overview	3
The Guardian Robot	3
3D Printing Articulating Joints	3
Add LEDs!	3
Prerequisite Guides	3
Components	4
Tools & Supplies	4
3D Printing	6
3D Printing BIG	6
Filaments	6
Slice Settings	6
Circuit Diagram	7
Wiring LEDs	7
Wiring	8
Measure Wire Lengths	8
Thread Wires	8
Tinning Wires	9
Tin LEDs	9
Wire Anode	9
Wire Cathode	10
Test LED Wiring	10
Drill Holes	11
Wire Joints	11
Wiring Perma Proto	12
Install JST On/off Switch Breakout	12
Wired Perma-Proto	13
LEDs are Awesome!	13

Overview

The Guardian Robot

This creature is one of the main "bad guys" in the video game, *Zelda: Breath Of the Wild*. It has six legs and a deadly laser beam that shoots out from the singular eye. It can certainly do some major damage to our hero, Link, but is no match for the Master Sword.

3D Printing Articulating Joints

This guardian robot was designed and 3D modeled by [Steve \(https://adafru.it/x5c\)](https://adafru.it/x5c). He shared his design on [Thingiverse as a free download. \(https://adafru.it/x5d\)](https://adafru.it/x5d) The head freely rotates apart from the body and the limbs are made up of segments, so they can articulate. The main body and head are printed in place!

After printing the Maker Faire Action Robot Figure my son and I sat down to design our own robot... My goal was to print the robot in as few parts as possible while ensuring that all of the joints printed cleanly.

What I like most about the design is how well it's optimized for FDM 3D printing. No supports required and minimal material for infill. The head, joints and parts of the body are hollow, so it's not using up a whole lot of material. Another benefit of hollowed parts allows for integrating electronics.

Add LEDs!

As this was mostly a weekend project, I was inspired to add LEDs to really make it come to life. I started out by drilling out a hole in one of the articulating joints and threaded wires through each of the segments that make up a limb. It worked out nicely, so I figured I'd document the project.

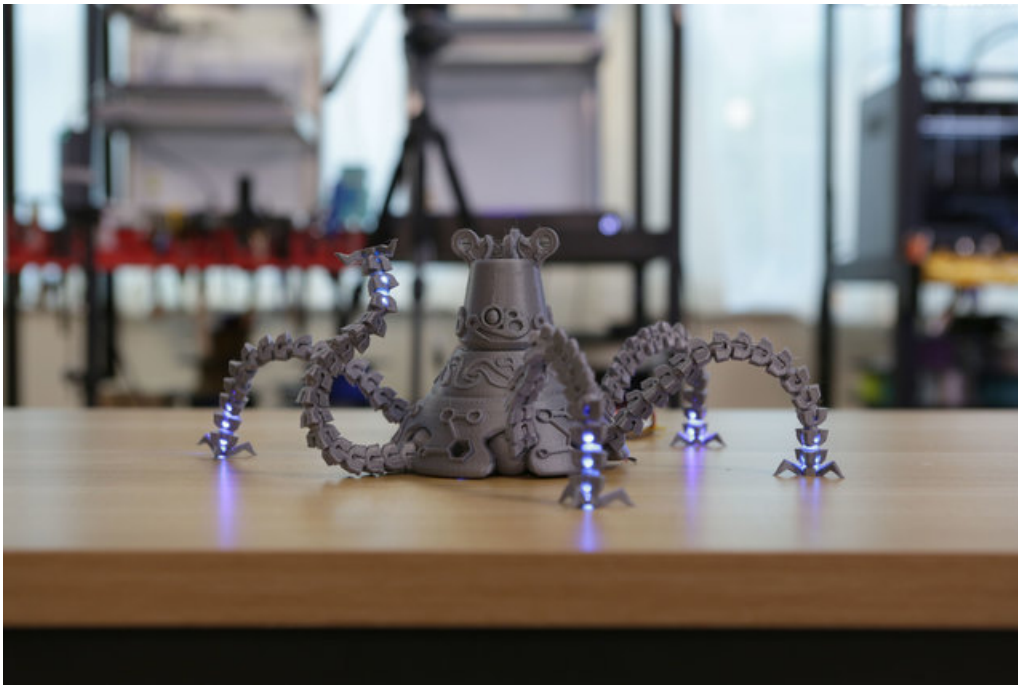

Prerequisite Guides

If your new to electronics and working with LEDs, I suggest you walk through the following guides to get basics of

wiring and soldering. The following guides will walk you through setting up LEDs.

- [Collin's Lab – Soldering \(https://adafru.it/wsa\)](https://adafru.it/wsa)
- [All about LEDs \(https://adafru.it/e3K\)](https://adafru.it/e3K)



Components

For this project, I used six 3mm LEDs, a breadboard PCB, JST breakout and a battery. No micro-controller necessary! Full list of parts are linked below.

1 x [Adafruit Perma-Proto](#)

Quarter-sized Breadboard PCB - Single

[ADD TO CART](#)

6 x [Blue LEDs](#)

Diffused 3mm blue LEDs

[ADD TO CART](#)

1 x [Battery](#)

150mAh 3.7V Lithium Ion Polymer

[ADD TO CART](#)

1 x [On/Off Switch](#)

JST-PH 2-Pin Breakout Board

[ADD TO CART](#)

6 x [Resistor Through-hole](#)

220 ohm 5% 1/4W - Pack of 25

[ADD TO CART](#)

Tools & Supplies

To put together the electronics, we just need a few tools like a soldering iron and some wire cutters. But using a

panavise and helping third hands just makes things easier.

1 x [Wires](#)

30AWG Silicone Cover Stranded-Core

OUT OF STOCK

1 x [Soldering Iron](#)

Heat Pen

BUY NOW

1 x [Panavise](#)

Holds Boards and Things Sturdy

ADD TO CART

1 x [Third Helping Hands](#)

Holds wires sturdy

ADD TO CART

1 x [Heat Shrink](#)

Adds insulation to exposed wires

ADD TO CART

1 x [Flush Diagonal Cutters](#)

CHP170

ADD TO CART

1 x [Wire Strippers](#)

Hakko 20-30 AWG - CSP-30-1

ADD TO CART

1 x [Helping Third Hand](#)

Includes Magnifying Glass Tool - MZ101

ADD TO CART

3D Printing

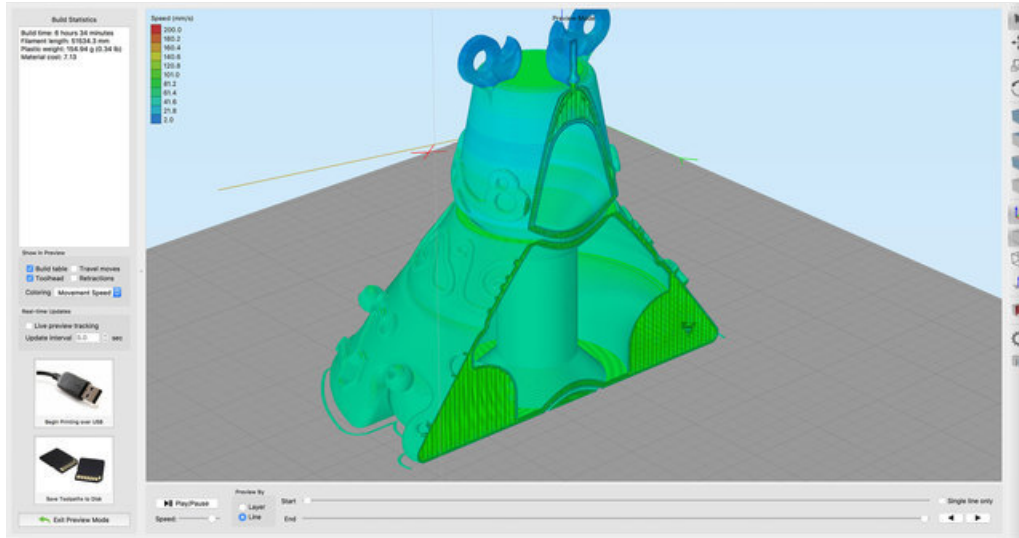

3D Printing BIG

The main body of the guardian robot is fairly large, dimensions of ~120mm x 122mm x 115mm. However, it should fit on most 3D printers with a build volume of around 150mm cubed. The parts do not require any additional support materials.

Filaments

I used silver/gray colored PLA material to print the body and the segments. This material can be printed without a heated bed and around 210-220c on the extruder temperature.

It'll take around ~155grams of filament (about \$7 in material costs). So be sure to have a fresh spool of plastic.

<https://adafru.it/x5d>

<https://adafru.it/x5d>

Slice Settings

I sliced the parts using Simplify3D. It's paid software license, but you can optionally use CURA which is free and open software. You'll have to adjust your slice settings to accommodate for your printers profile. The tolerances may slightly vary from printer to printer.

- 0.4mm nozzle
- 1.0 (100%) extrusion multiplier
- 0.48mm extrusion width
- 2 shells with 5 top/bottom layers
- 20% infill
- 90mm/s print speed - 200mm/s movement

Circuit Diagram

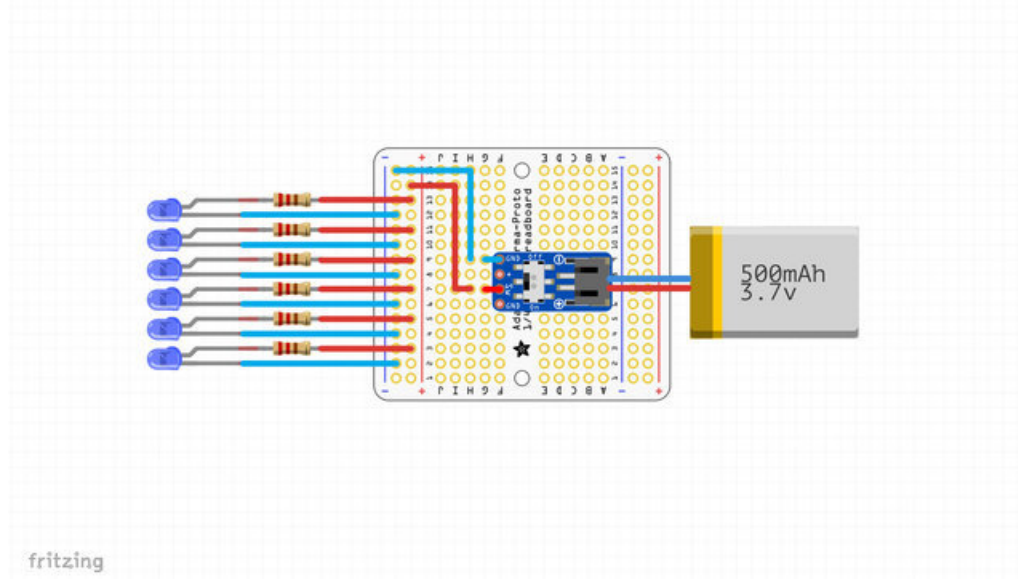

Wiring LEDs

There are six LEDs used in this project, each needs two wires – That's a total of 12 wires. Each LED needs a [220ohm](https://adafruit.it/x5e) or 330ohm current limiting resistor. We'll connected all of the wires into a quarter size Perma-Proto breadboard PCB. To power the LEDs, we'll connect a switched JST breakout board to the perma-proto. A 3.7V Lithium ion polymer battery will supply the voltage.

This provides a visual reference for the wiring of the components. They aren't true to scale, just meant to be used as reference.

Wiring

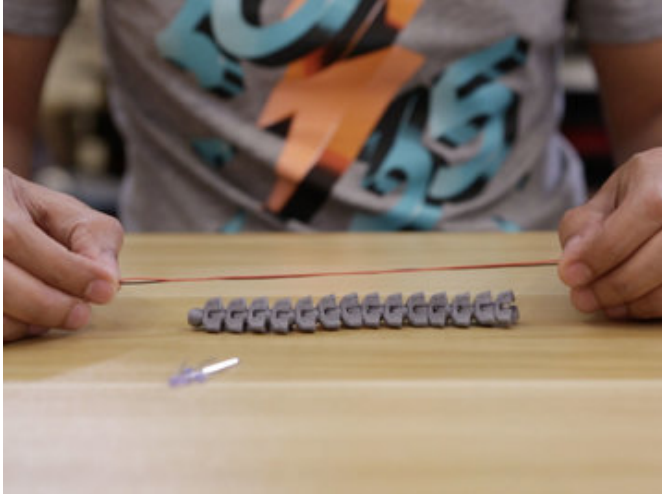

Measure Wire Lengths

First step is to figure out how long our wires need to be. In order to do this, we'll need to assemble one limb. Each limb is 15 segments. Each segment snaps together, forming an articulating limb. A whole assembled limb is roughly 6in (15cm) in length. Our wires will have to be longer than this. Mine were about 9in (22cm). The extra length accommodates for the distance needed to wire into the breadboard PCB.

It's good idea to use different colored wires to help tell the connections apart.



Thread Wires

Once I have all of my wires measured and cut to size, the next step was to install them into each limb. To do this, I threaded the wire through each individual segment. It was easier this way, as the wire would get caught when trying to thread it through the whole limb assembly. This was very reminiscent to building popcorn necklaces.

Tip: I found it necessary to add a piece of masking tape to one of the ends – This prevents the wire from accidentally slipping out of the segments.

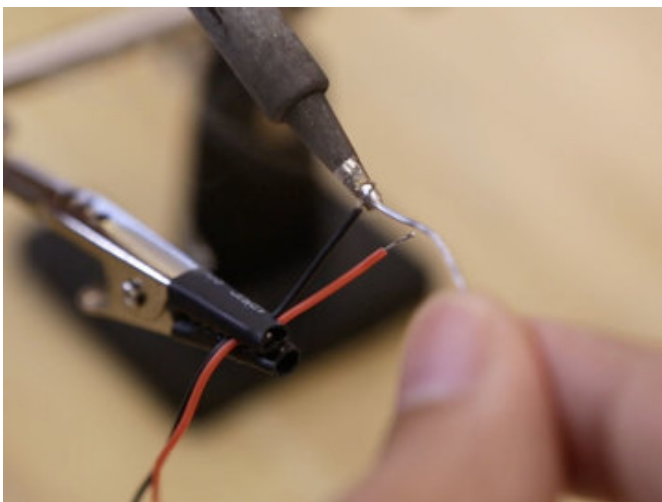

Tinning Wires

After I had the wires threaded and installed into each limb, next I worked on tinning all of the tips. Since I'm using 30AWG silicone cover stranded core wire, it's a good idea to tin them. First, I needed to strip each wire using a pair of wire strippers. I highly recommend using a pair of helping third hands to hold the wires in place while applying solder.

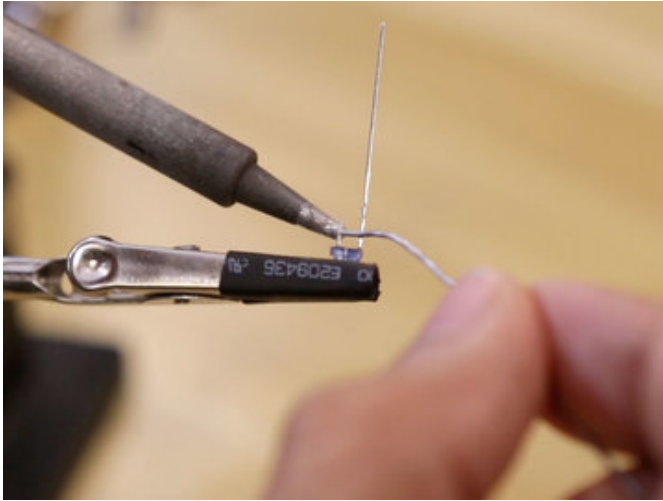

Tin LEDs

Next I needed to work on prepping the LEDs for wiring. First, take note which electrode is positive (anode) and which is negative (cathode). Normally, the positive anode has a longer leg. Then, I trimmed the anode short using flush cutters. After that, I tinned it by applying a small amount of solder.

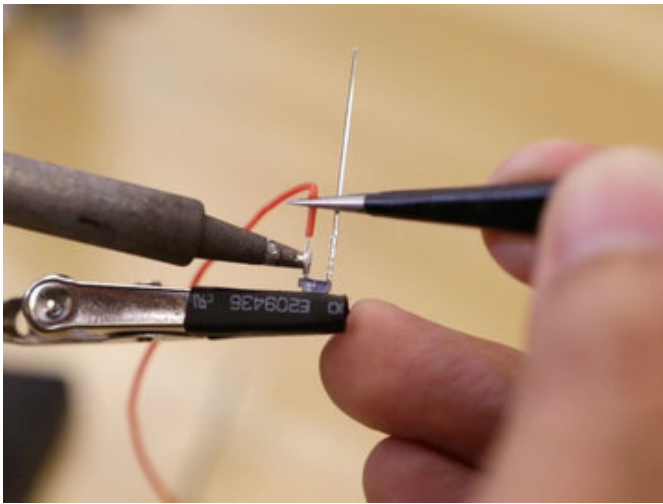

Wire Anode

With the anode tinned, it's ready to wire up! Before wiring, I made sure to add a small piece of heat shrink tubing to one of the wire that are threaded through the limb. Then I attached it to the anode by soldering it in place. Slide the heat shrink over the exposed wire and apply heat to shrink.

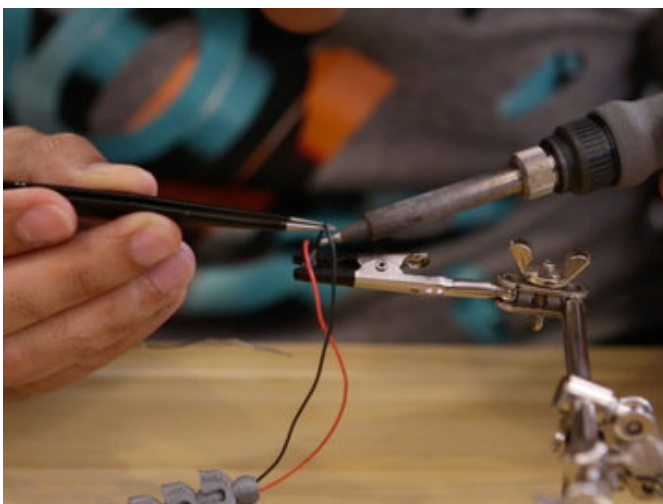

Wire Cathode

After our anode is wired, we can work on wiring the cathode. Basically repeat the same steps as we did for the anode. Optionally add heat shrink tubing for the cathode. I found using tweezers to hold the wires close to the cathode was very helpful. Keeps my fingers away from the tip of the hot tip of the soldering.

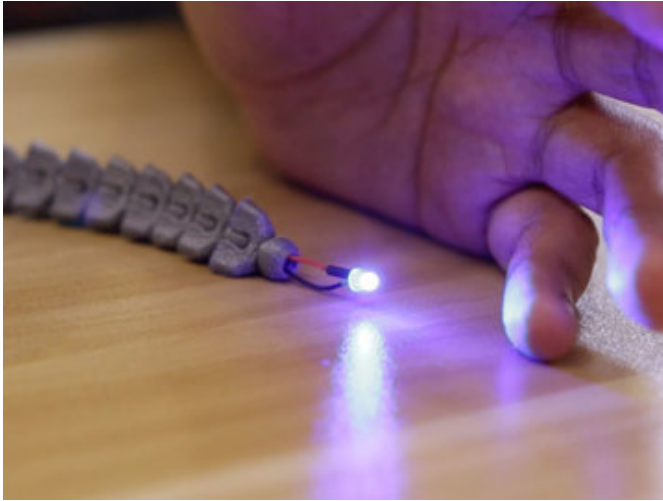

Test LED Wiring

Using a [3V coin cell battery](https://adafru.it/dPG) I quickly tested to see if I had correctly wired the LEDs. This is done by placing the negative (cathode) wire onto the negative side of the coin cell, and the positive (anode) wire to the positive side of the coin cell. If everything is wired correctly, our LED lights up! Next, we'll need to repeat this process for the rest of the limbs. It's a bit of process, so feel free to take breaks.



Drill Holes

Once I had all of the LEDs wired up and tested, I needed to through them through the joints in the main body. To do this, I had to drill 4mm holes into each joint. It's easy to do with a rotary power tool like a Dremel. On the flat side of each joint, I marked two lines to find the center and drove the tip of the drill bit into the joint.

PLA tends to melt/gunk up under friction and heat, so drill shallow and slowly.

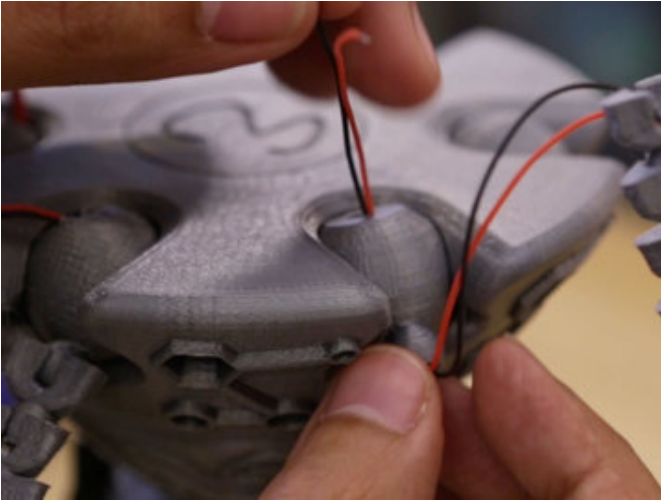

Wire Joints

After drilling out all of the necessary holes, I needed to thread each wire through the joint. Insert a single wire through the smaller sphere and out through the large joint. Pull the wire through and repeat for the second wire. I found it a bit difficult to thread the wires, so I ended up drilling larger holes in each joint.

Wires larger than 30AWG may not fit through the joint.

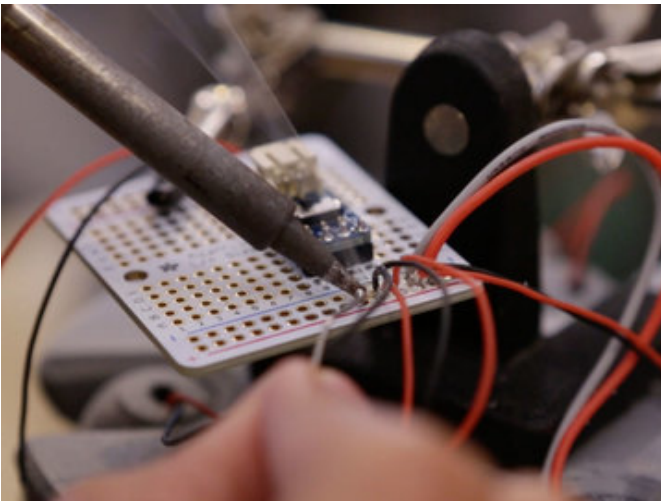

Wiring Perma Proto

Now that all of the wires are threaded through the joints, we can wire them into the perma-proto PCB. They can be soldered into any of the power and ground rails (marked blue for negative (cathode) and red for voltage (power, anode, positive)).

Install JST On/off Switch Breakout

I attached the JST breakout board to the perma-proto by soldering header pins (included with the breakout) to the PCB. Then, placed the header pins into available pins on the perma-proto. Solder the headers in place. The headers should be placed in pins that are across from each other, not "down" the row. Note how the rows are connected but

the columns going across are not. This is how most breadboards work. The numbers correspond to the columns.

If you're new to electronics and want more detail, please follow the circuit diagram and walkthrough the prerequisite guides.

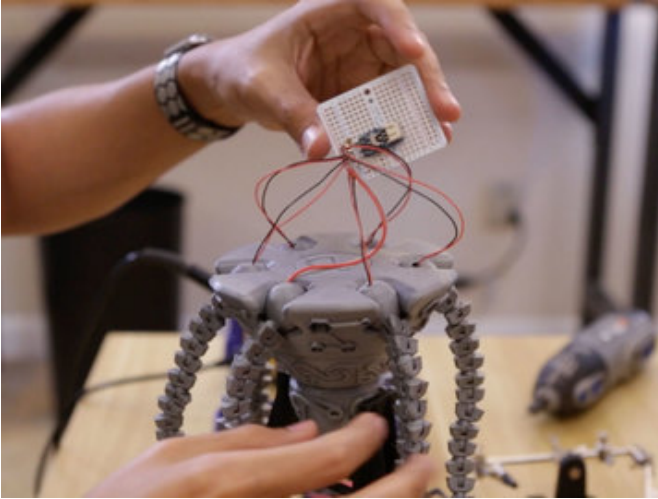

Wired Perma-Proto

And with everything wired into the perma-proto, we can now test it out! Plug in the male JST connector from the lipo battery into the female JST connector on the JST breakout board. Make sure the on/off switch is in the ON position. The blue LEDs will shine bright.

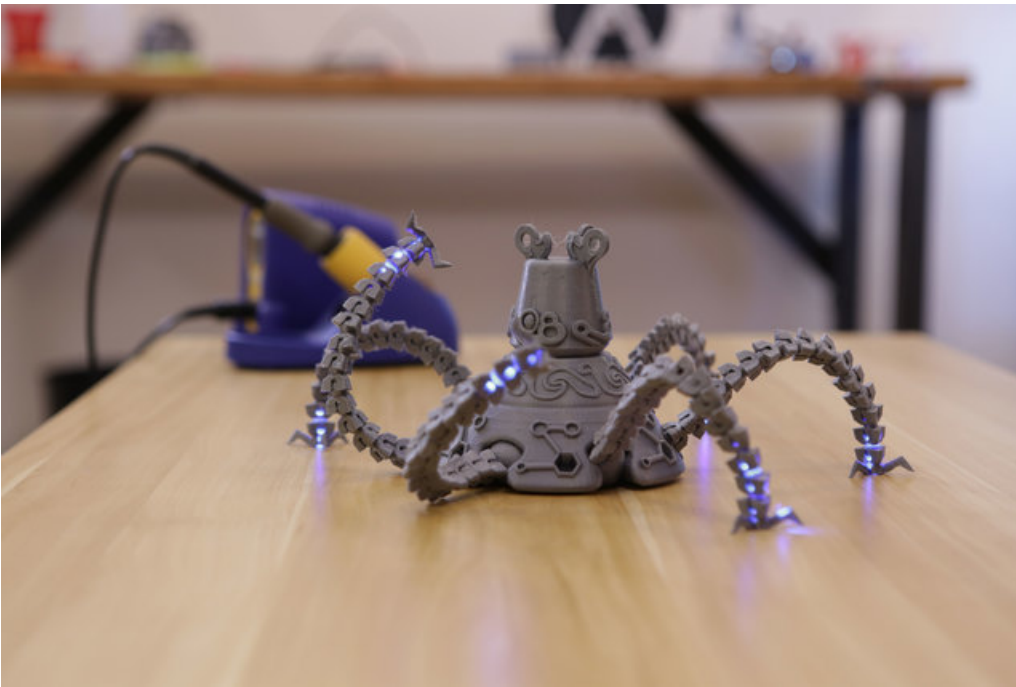

LEDs are Awesome!

And that's it for this project. It's really more of a proof of concept / prototype. There's a lot of room for improvements. From an electronics stand-point, we could wire the LEDs into an IoT board like the [Adafruit HUZZAH ESP8266 \(https://adafru.it/x5f\)](https://adafru.it/x5f) and Adafruit IO with IFTTT (If This, Then That) to have the LEDs trigger whenever you get notifications. We actually have a [project that does exactly this \(https://adafru.it/x5A\)](https://adafru.it/x5A).