



3D Printed LED Goggles

Created by Rick Winscot



<https://learn.adafruit.com/3d-printed-led-goggles>

Last updated on 2021-11-15 06:06:07 PM EST

Table of Contents

Overview	3
Tools / Materials	4
3D Printing	5
Bridge Assembly	5
NeoPixel Rings	11
Lenses	14
Wire, Strap, and Extras	15
Make Um' Blink Um'	19

Overview

[We luv our NeoPixel Goggles project \(https://adafru.it/cGs\)](https://adafru.it/cGs)

However, if you prefer to make a pair of steampunk goggles rather than mod something off-the-shelf... you've come to the right place.

This tutorial project uses the same parts but swaps the off-the-shelf goggles for 3D printed versions



Props to gianteye for the [models \(https://adafru.it/cQQ\)](https://adafru.it/cQQ) on Thingiverse on which my goggles are based. He does some crazy awesome work.

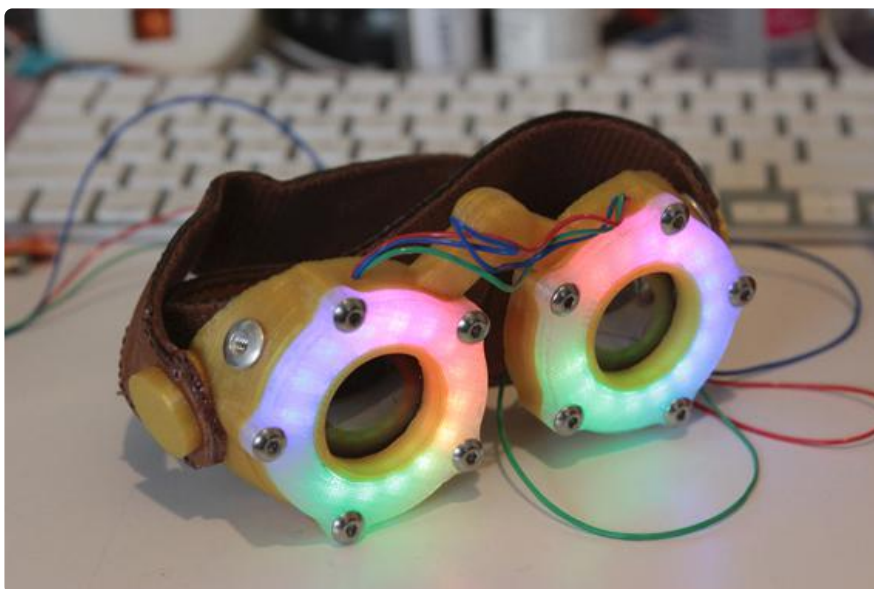

Tools / Materials

Let's start with the items that you'll have to get from your local home improvement store.

10 X 8mm 8-32 screws and a 2.5mm allen wrench to secure the lenses. If you stroll down the hardware aisle, you'll see all kinds of alternatives if this particular type doesn't suit your fancy.



1 X 8mm M3 Screw, Nut, and a paper washer for the bridge.

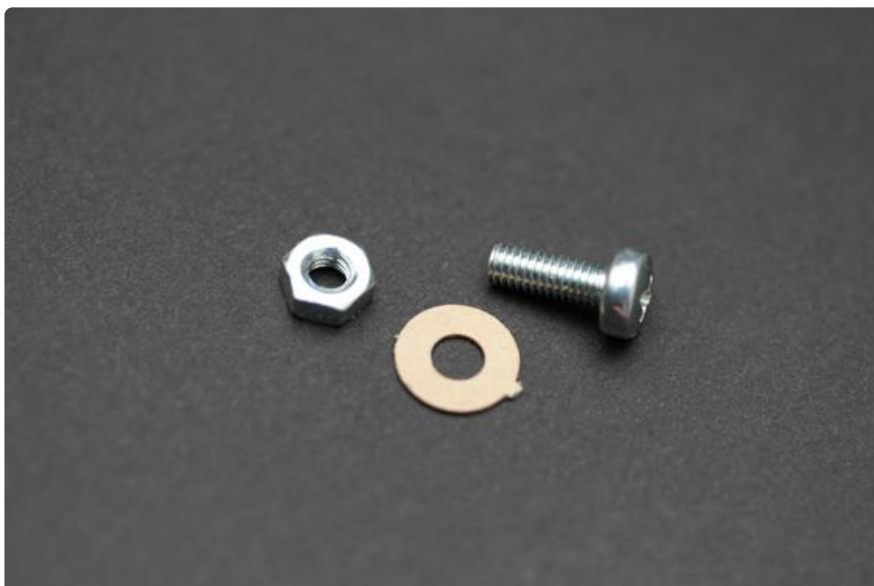

Add to this some epoxy and super glue - Gorilla brand is highly adequate. And... some 220 grit sand paper.

3D Printing

The great part about making a pair of goggles is that you have total control on how they look!

In fact, I found some great looking gold and natural PLA from [Matterhackers.com](https://matterhackers.com) (<https://adafru.it/cQR>) that looks like brass; a steampunk classic.

When you're ready, download these 3D models...

3D Models (.stl files)

<https://adafru.it/cQS>

...and fire-up your 3D printer.

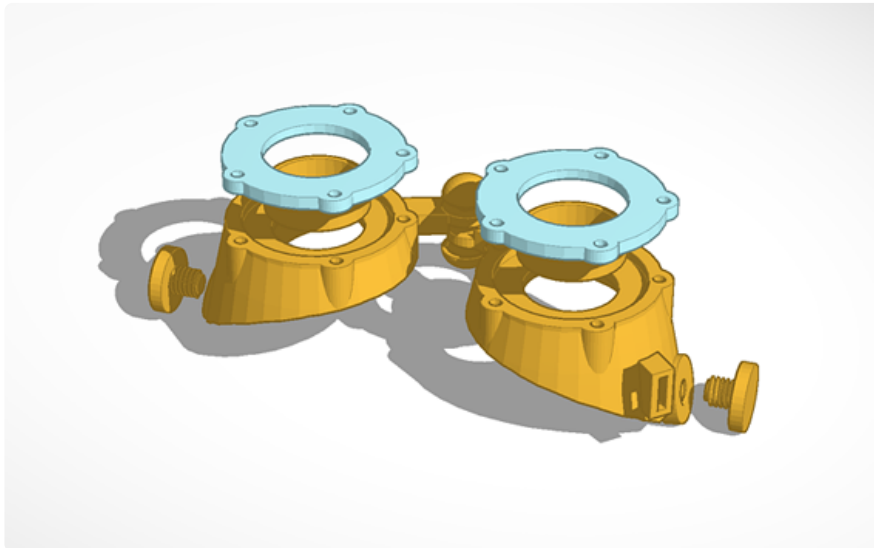

For reference, there is an [exploded view](https://adafru.it/cQT) (<https://adafru.it/cQT>) of the goggles over on Tinkercad.

Bridge Assembly

Grab your M3 screw, nut, and paper washer.

Remember, slow and steady wins the race - using the force may cause the PLA to crack.

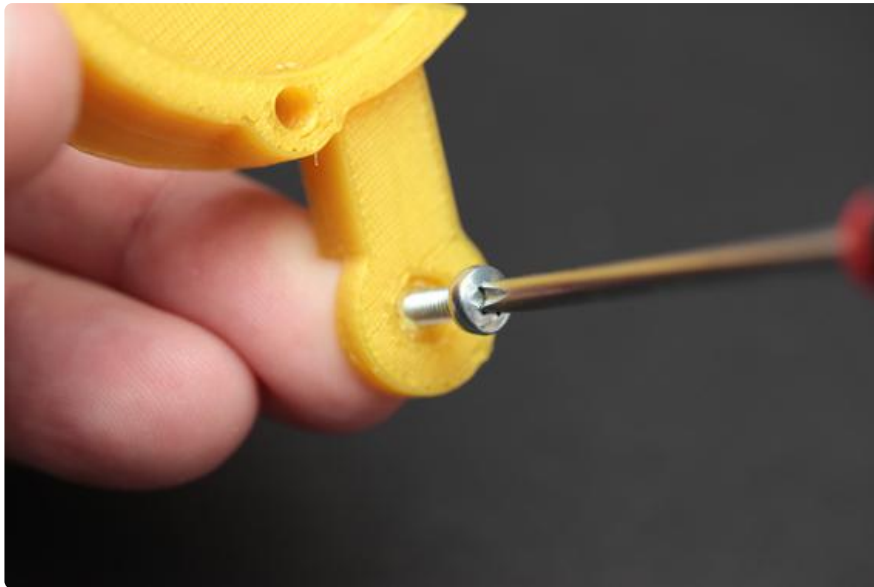

Add the paper washer between... to smooth bridge adjustment.

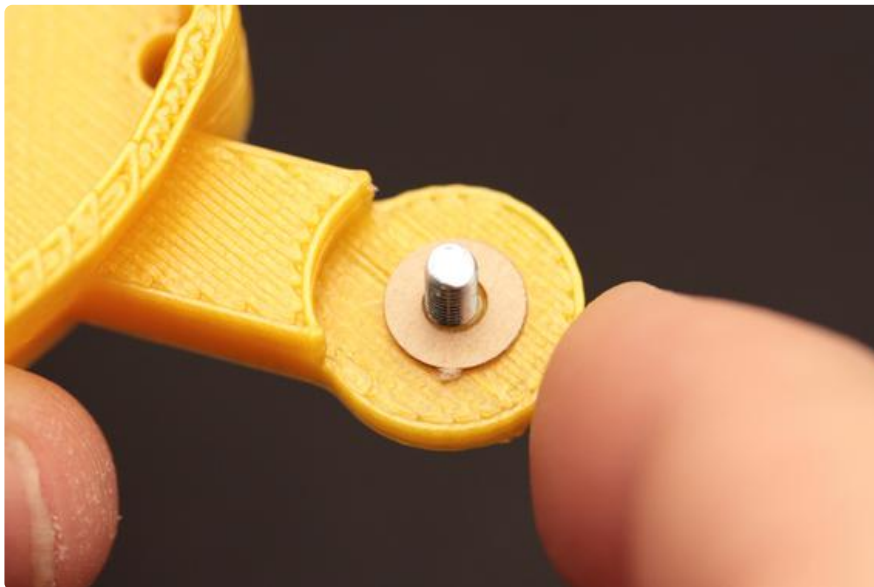

Add the nut on the back.



Put a glop of super glue or epoxy on the treads of the screw, over the nut, and onto the plastic. We need to make sure that the bridge won't go loosey goosey over time.



To help secure the screw and nut to each other, you can back the screw out a bit to get the glue to wick down into the nut... then tighten.

Make sure to let the glue dry fully before the next step.

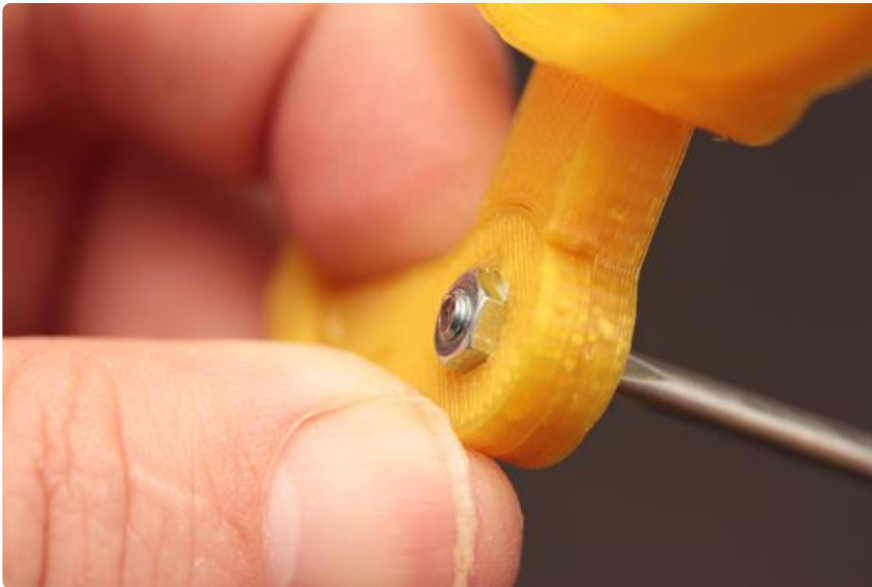

Grab your grits and acquire a flat surface - sand both caps.



Make it smooth... and make it flat.



Just a dab of super glue will do on the caps.



Cover the screw with the cap.



And the other side.



The caps are optional, but I like the look of the bridge with the screw / nut covered.



NeoPixel Rings

Insert the ring, and put a mark next to the ground, power, and in / out pins.



PLA is typically more brittle compared to ABS. Drilling may cause ugly tear-outs and weakens your prints.

An alternative, would be to use a soldering iron to make the hole next to your marks.



I had some one-way lenses from an old webcam in my parts drawer... perfect for lenses in the goggles.

The silver mylar part bags that most electronics come packaged in look just as good. Cut to fit, and glue to the tubes.



Then glue the tubes to the eye-cups.

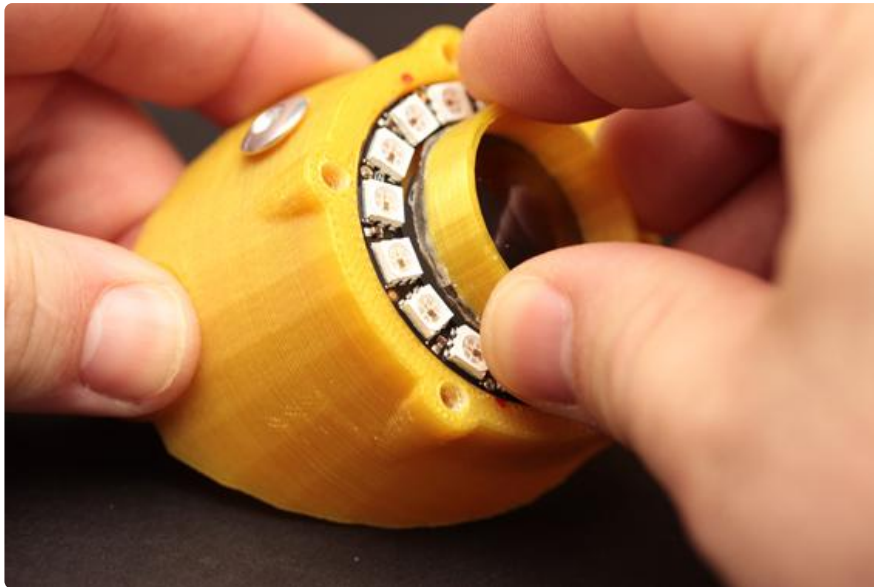

The rounded lens has a strange "I'm looking at you" effect.

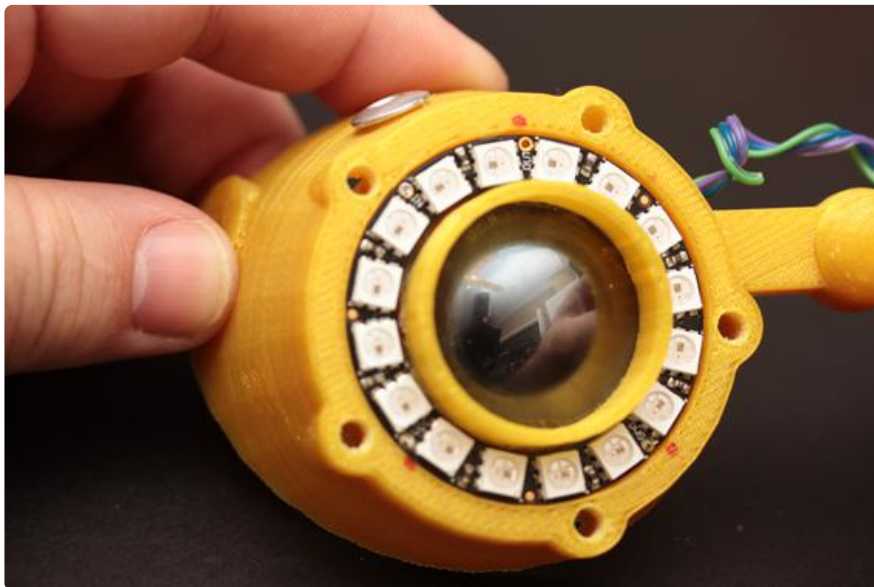

Okay... wiring is not so pretty - but it works!

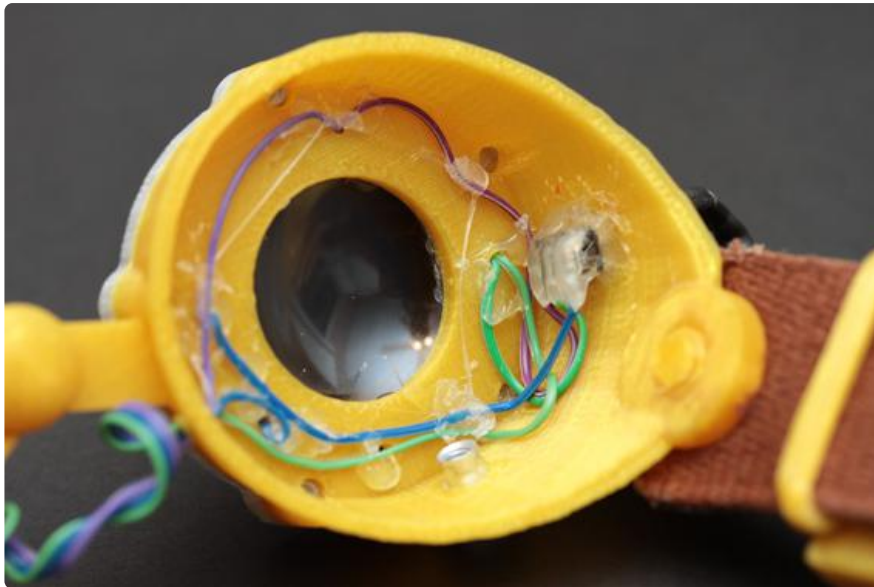

Lenses

It's a little difficult to see, but one side of the lens has an indent.

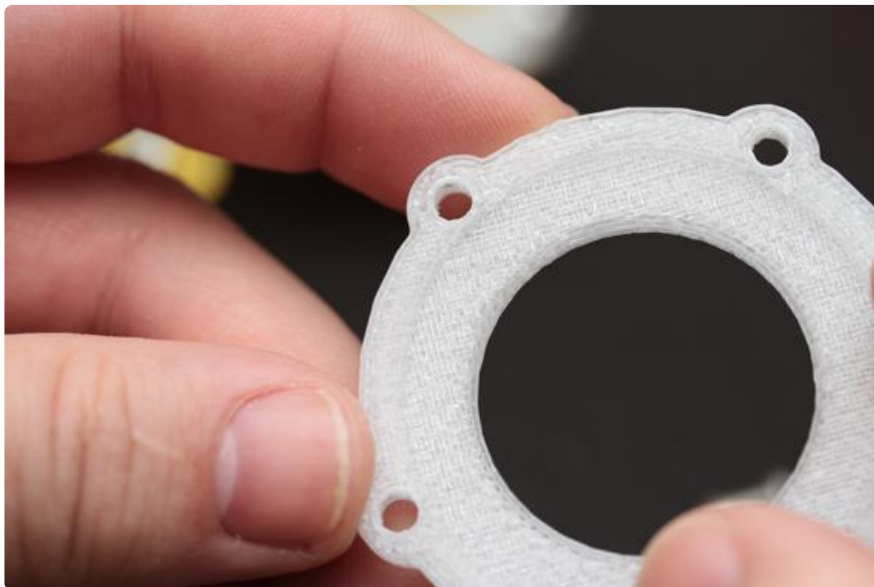

This is the side that faces the eye-cup and sits on top of the LEDs in the ring.

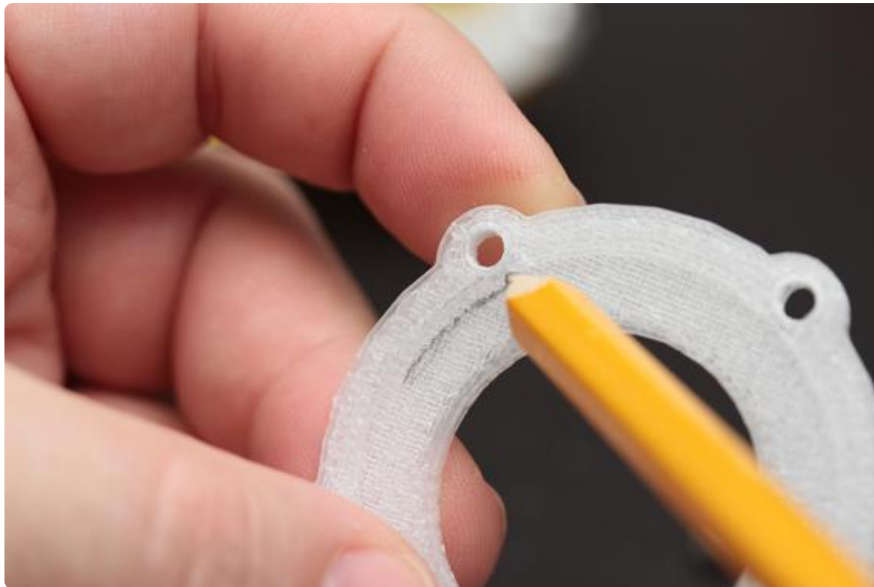

(the mark is just to help show you where the recess is at)

Next, secure the lens with your hardware of choice. If the tolerance between the screw and the plastic is too tight, consider tapping the hole first.

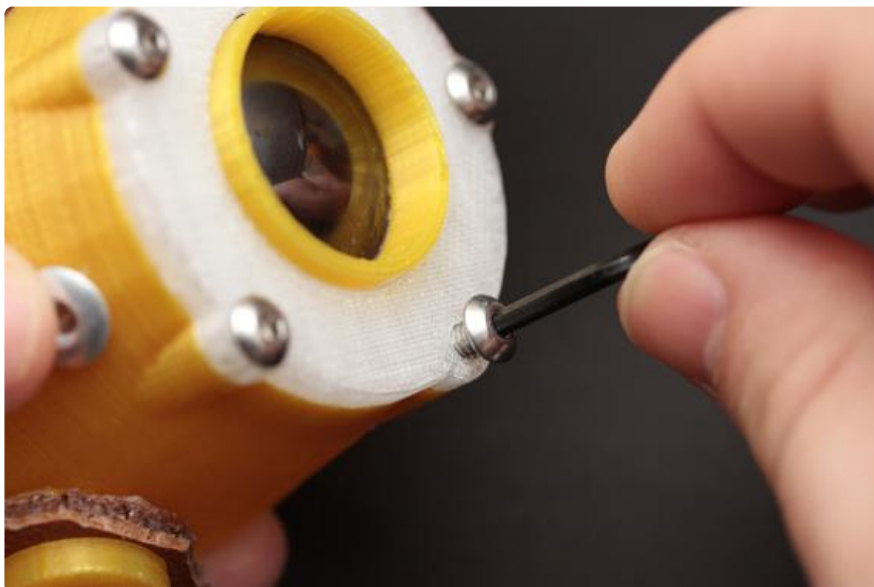

Wire, Strap, and Extras

When running the wires between sides, you can use the same soldering iron technique we used on the face of the goggles.

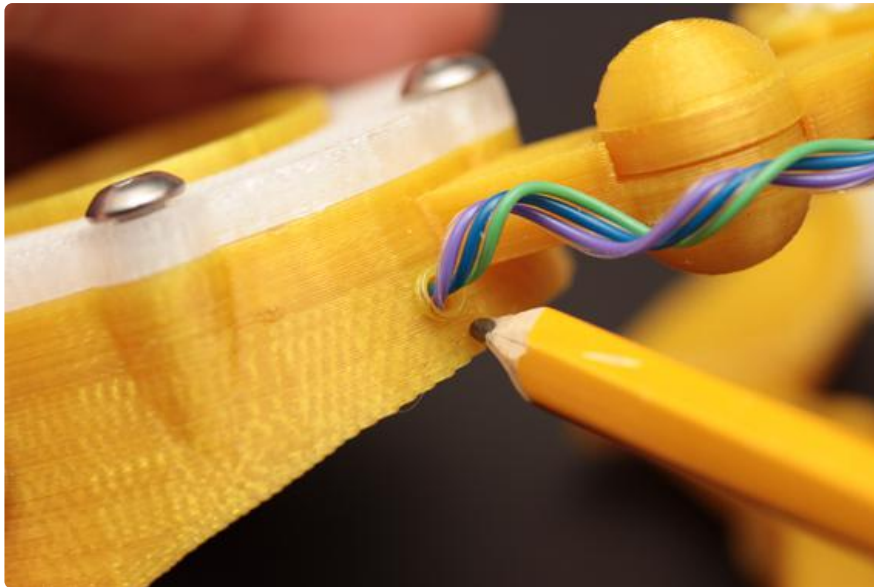

I added a fancy four-port socket on the side of one of the eye-cups with a little epoxy.



Which fits a standard four pin plug.

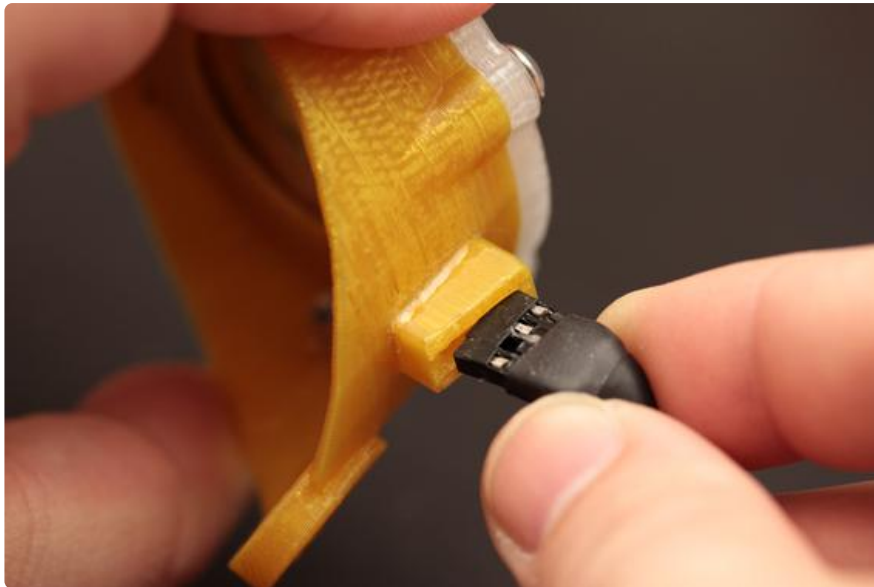

Notice that I've used only three of the connections - so that the socket and plug are polarized.

Connect the ground, power, and data line to a Trinket, Gemma, or Arduino. [Our other LED-goggle tutorial has details on how to use a Trinket, with some example code as well \(https://adafru.it/cGs\)](https://adafru.it/cGs)



3D printed threads are going to be troublesome. Print on a fine setting with a slow speed and be prepared to do some careful clean-up on the parts to make sure they fit together well.

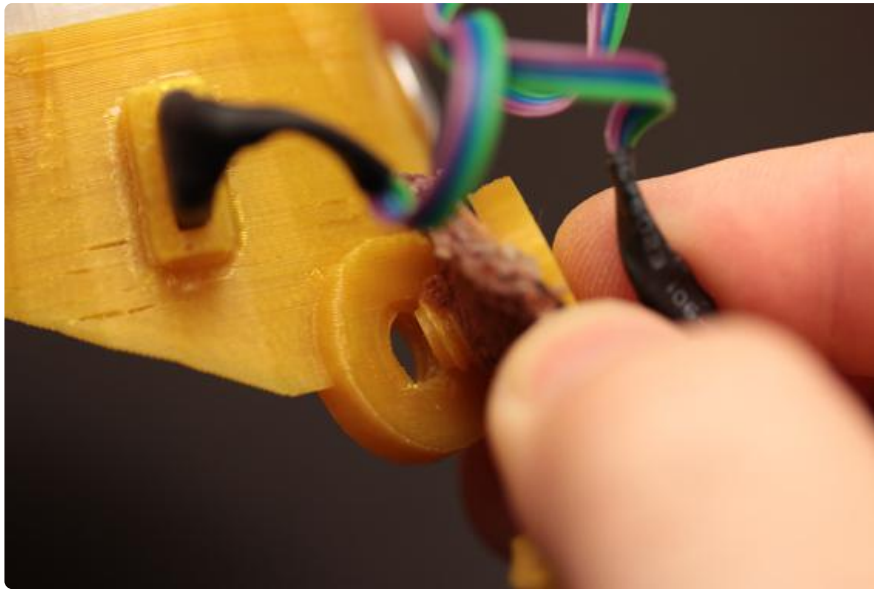

Use an old leather belt, strap from a purse, or nylon ribbon as a head band for your goggles.



Accessorize with hardware to your hearts content.



Here, I added a port made from one-half of a scrap book page post.

Make Um' Blink Um'

There are more than a [dozen](https://adafru.it/kA3) (<https://adafru.it/kA3>) guides in the Adafruit Learning System with code samples on how to animate NeoPixel rings... here are two great ones to get you started!

- [STEAM-Punk Goggles](https://adafru.it/kA4) (<https://adafru.it/kA4>)
- [Kaleidoscope Eyes](https://adafru.it/kA5) (<https://adafru.it/kA5>)

You can even use the NeoPixel Strand Test example straight out of the Arduino IDE for a very nice rainbow effect.