

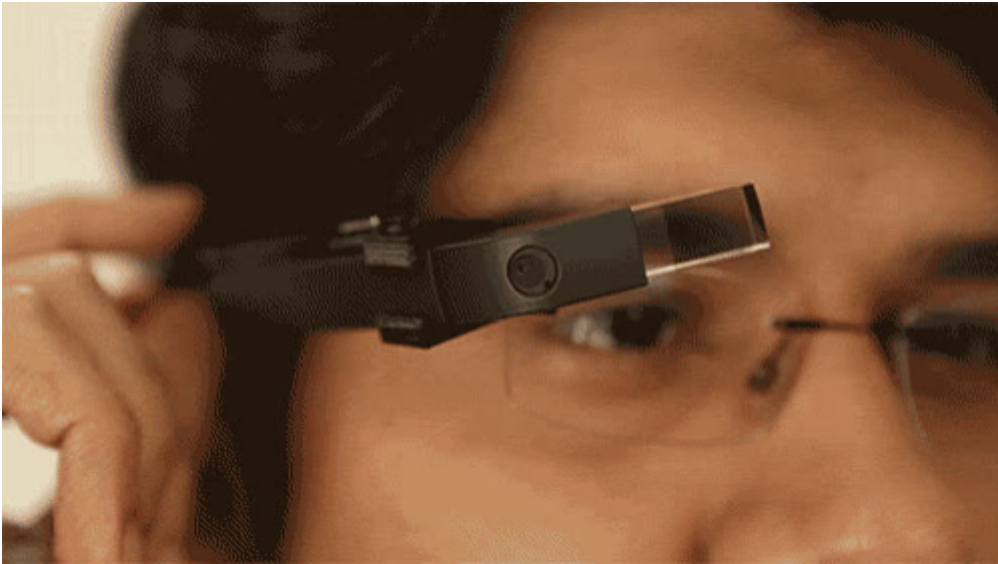

3D Printed Google Glass Adapter

Created by Ruiz Brothers



<https://learn.adafruit.com/3d-printed-google-glass-adapter>

Last updated on 2024-06-03 01:27:35 PM EDT

Table of Contents

Overview	3
• Tools	
Disassembly	5
Measure & Customize	7
3D Printing	12

Overview

Upgrade your google glass with your own frames using a 3d printed adapter.

A new pair of google glass frames will set you back about 200 bucks, but we can 3d print an adapter for under 1 dollar in material.

A 3d printed plastic adapter turns any frame into prescription google glasses.





Tools



[Calipers](http://adafru.it/294) (<http://adafru.it/294>)

[T5 Screwdriver](http://adafru.it/452) (<http://adafru.it/452>)

[3D Printer](https://adafru.it/d9z) (<https://adafru.it/d9z>)

Disassembly



Removal of the device from the frames is very easy. Just locate the screw next to the eye sensor.

Make sure to power down Glass before you start. The touch track is sensitive and will easily trigger.



Unscrew using a [T5](http://adafru.it/452) (<http://adafru.it/452>) from our [Precision Trox Screwdriver Set](http://adafru.it/452) (<http://adafru.it/452>). It only takes three turn to detach the frame. The screw is held in place by a metal backing on the inside, so it shouldn't fallout.



Gently detach the main device from the frames by slightly turning the device downward while pull the frames towards your body.

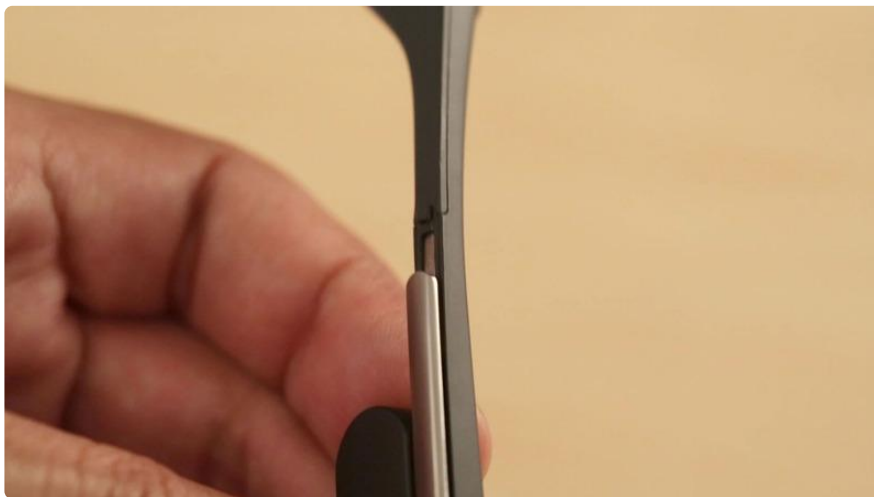

Now we'll slide the temple out of the groove.



Slightly push the frames downward to remove the main device.



Measure & Customize

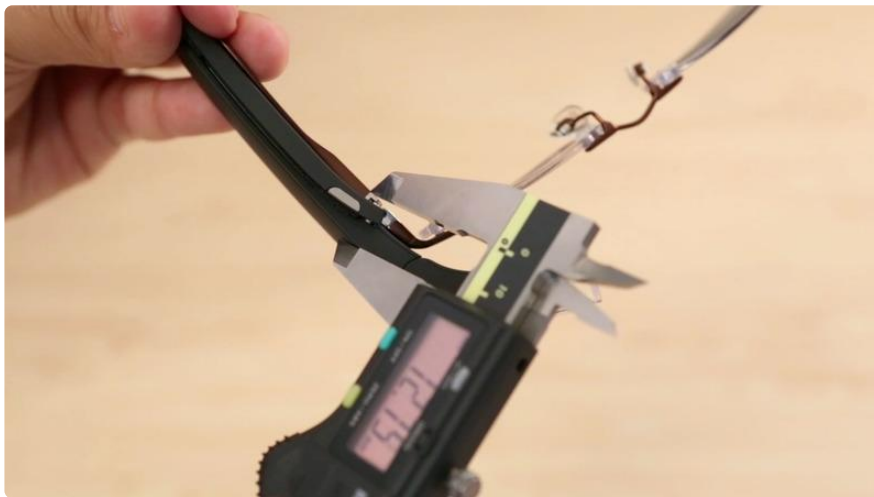

Align your frames up with Glass and take note of where the end pieces and hinges meet.

Measure and write down the depth of the front clip.



Measure where the temple and the end tips meet. Jot down the temples depth and height.

[Download Clips](#)

<https://adafru.it/d9A>

Download the 123D file to adjust the walls of the grooves that will latch on to your frames.

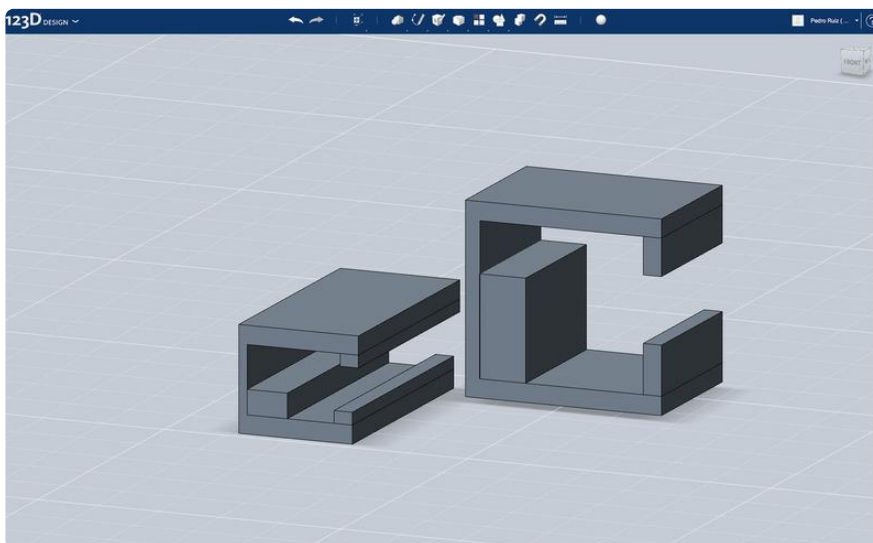

These groove were modeled for a thin design, so we've included un-combined geometry to easily adjust for larger frames. The front clip's inside area for Glass measures 9.66mm. The temple clip's inside area measures in at 3.80mm.

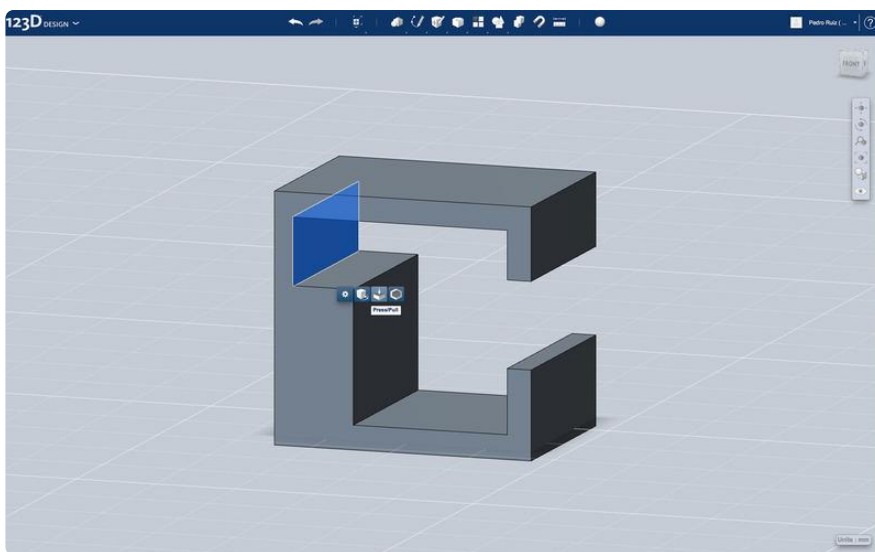
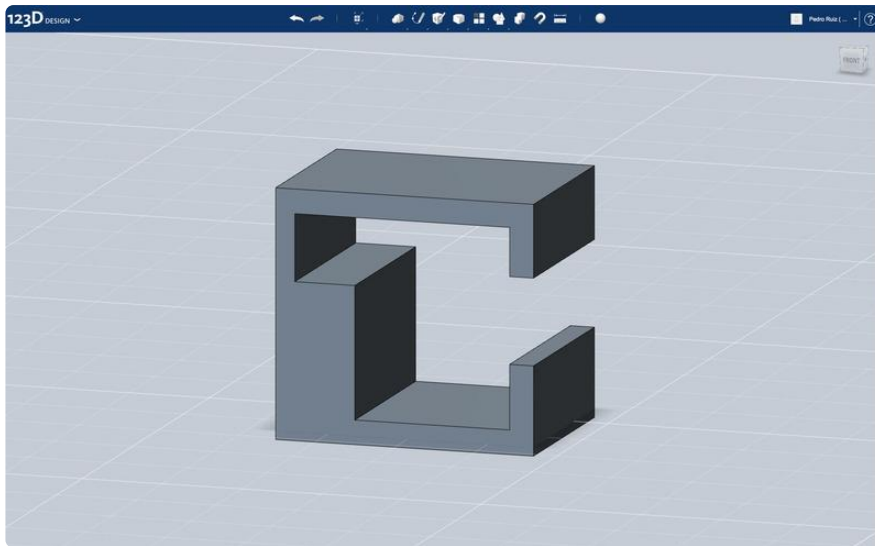

The wall for the front clip is adjusted by selecting the objects face and choosing the Press /Pull option.

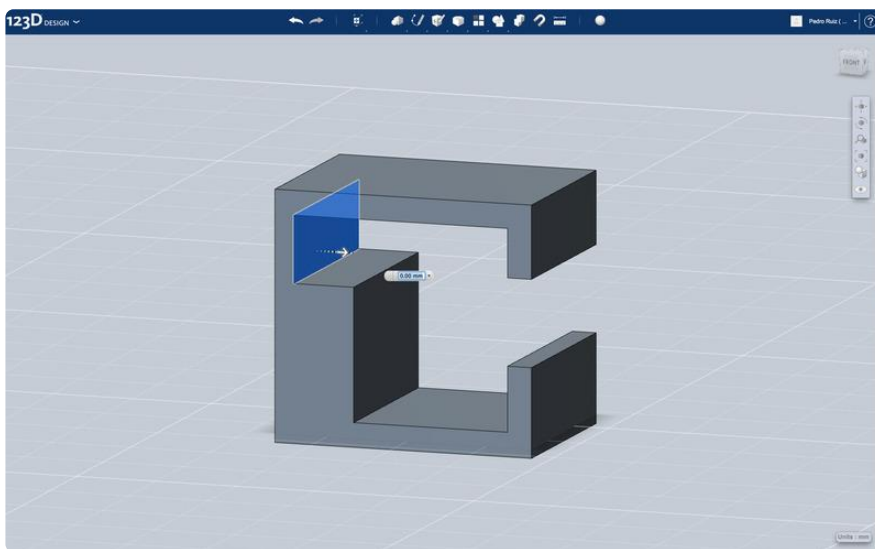

Drag along arrow's line or type in the value for the end piece and hinge measurements.

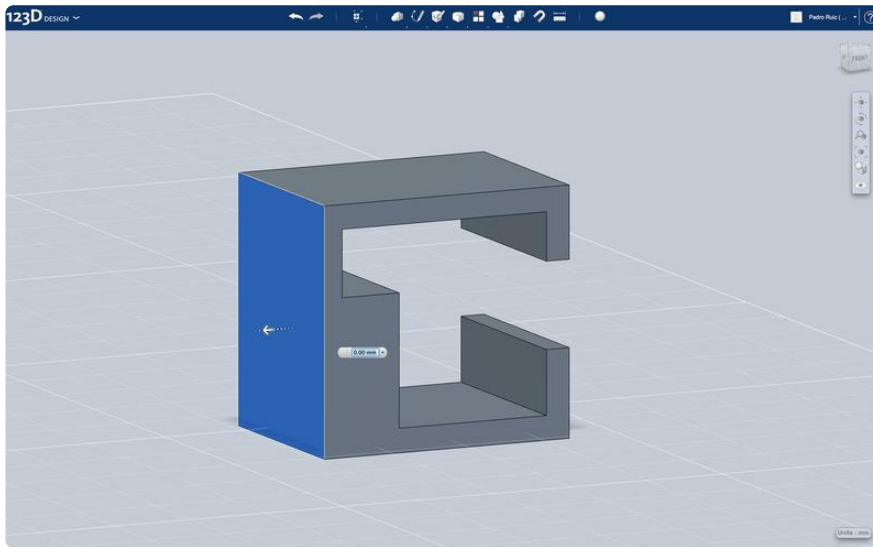

Remember to leave at least a .8mm of wall thickness on the other side of the clip.

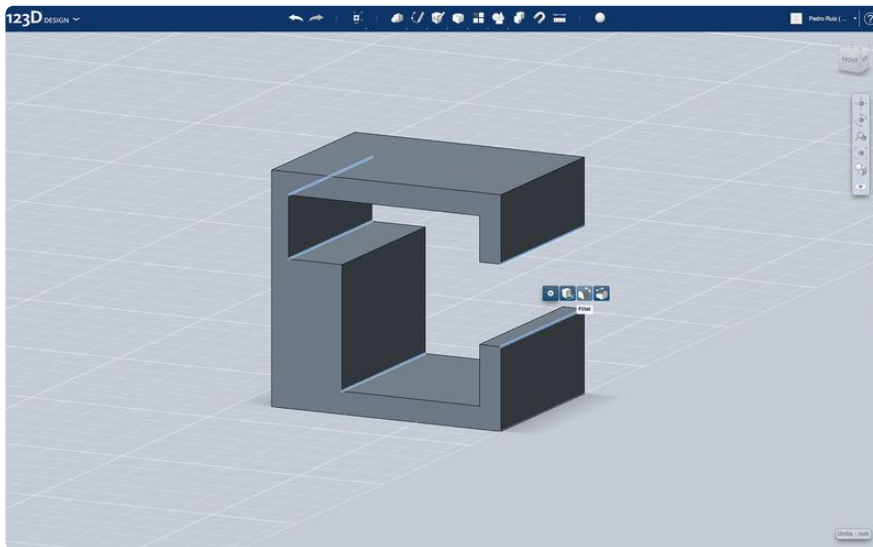

Add fillets to allow the clip to easily snap on and maintain a tight grip around Glass. Select the the edges shown and click on the tools gear to bring up your modifier options.

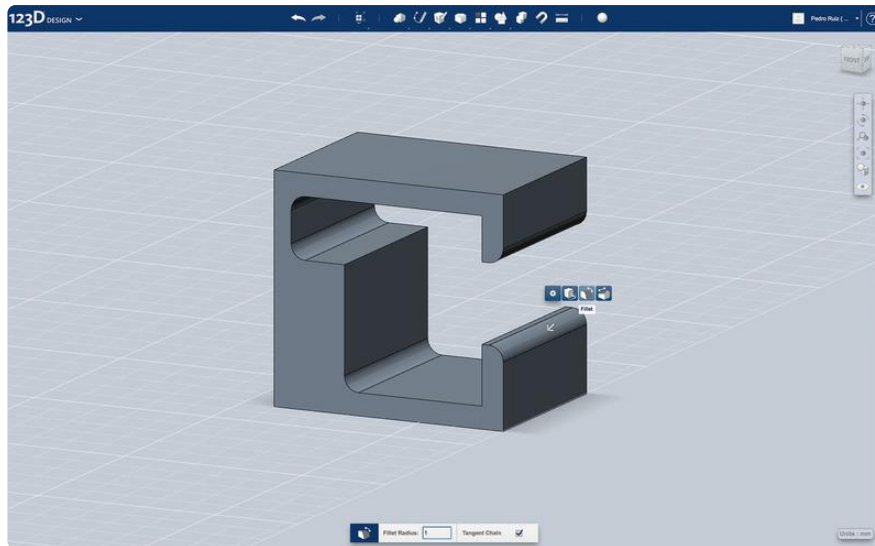

Fillet radius of 1 should be enough to round out the edges. Add additional fillets to the inside of the groove to curve around and firmly grip on to the frames.

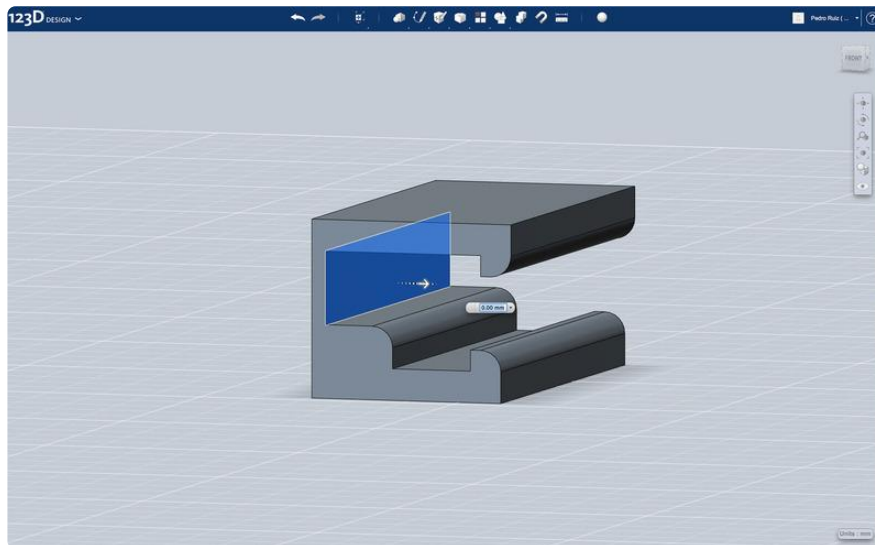

Do the same to the temple clip part. Punch in the wall depth and add fillets. Depending on your frames, you may need to increase or decrease the length of the whole clip.

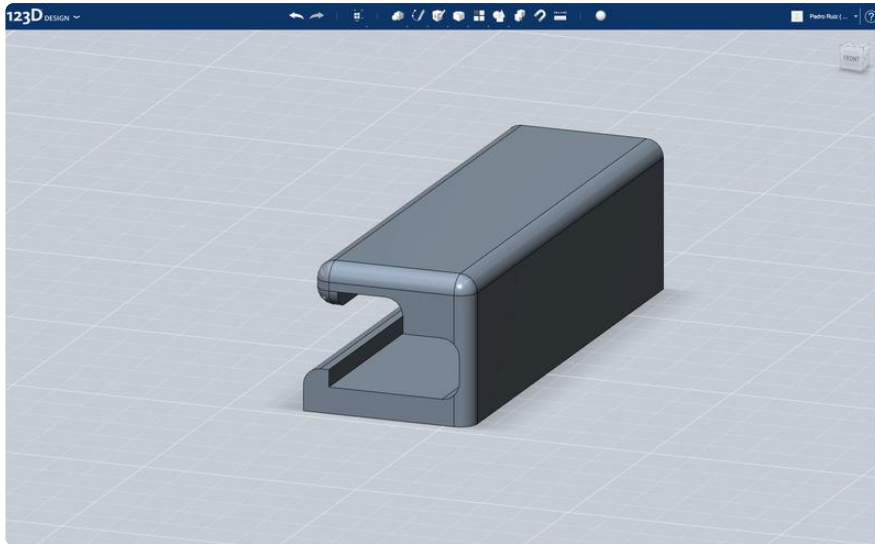

If the clip needs to be shorter, because of the temple curve of the ear, we can bevel sides for a more comfortable piece.

3D Printing

After you've [customized the model file \(https://adafru.it/19NB\)](https://adafru.it/19NB), you can set up to print.

Front Clip About 7 mins	PLA @230 No Raft No Support	2 shells 10% Infill 2.0 Layer Height 90/150mm/s
Back Clip About 15 mins	PLA @230 No Raft No Support	2 shells 10% Infill 2.0 Layer Height 90/150mm/s

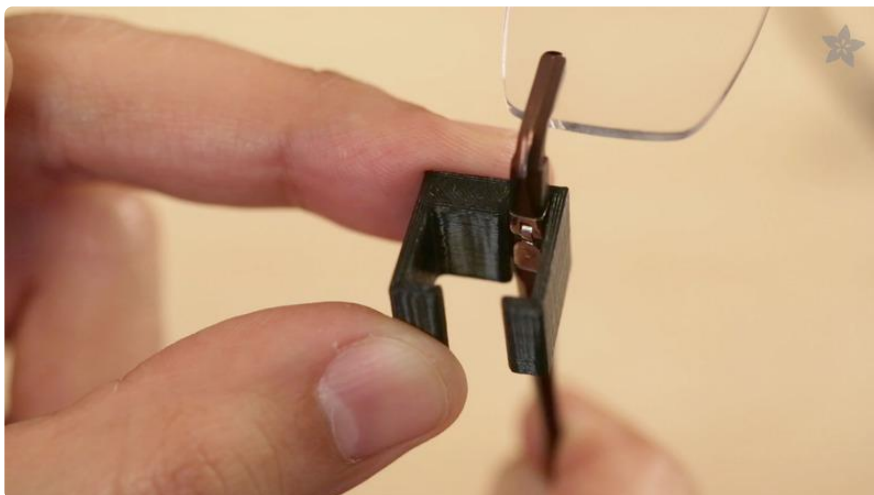

Check that the groove fits your frame hinge, we want it to grip tightly around the clip.



The back clip should snap fit on to Glass with snug hung around the temple.

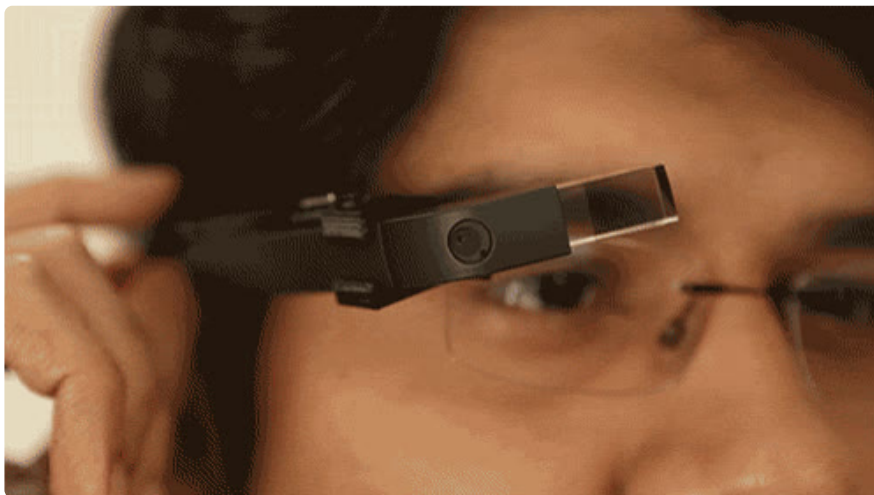

The fillet curves inside the temple clip allows Glass to adjust in and out of your field of view!

