

# 深圳秦唐盛世科技有限公司

## SPECIFICATION OF LCD MODULE

MODULE NO.: QT020HLCG00

Customer Approval:

Accept

Reject

ES	SIGNATURE	DATE
PREPARED BY		
CHECKED BY		
APPROVED BY		

### DOCUMENT REVISION HISTORY

<b>Sample Version</b>	<b>Doc. Version</b>	<b>DATE</b>	<b>DESCRIPTION</b>	<b>CHECKED BY</b>
01	A	2017-06-01	First Release.	

## CONTENTS

<b>List</b>	<b>Description</b>	<b>Page No.</b>
<b>1</b>	GENERAL DESCRIPTION	4
<b>2</b>	MECHANICAL SPECIFICATIONS	4
<b>3</b>	BLOCK DIAGRAM	5
<b>4</b>	DIMENSIONAL OUTLINE	6
<b>5</b>	PIN DESCRIPTION	7
<b>6</b>	TIMING CHARACTERISTICS	8
<b>7</b>	ELECTRICAL CHARACTERISTICS	8
<b>8</b>	AC CHARACTERISTICS	10
<b>9</b>	OPTICAL CHARACTERISTICS	11
<b>10</b>	PACKAGE	13
<b>11</b>	RELIABILITY	14
<b>12</b>	SPECIFICATION OF QUALITY ASSURANCE	15
<b>13</b>	GENERAL PRECAUTIONS	24

## 1. GENERAL DESCRIPTION:

Display & LCD Type: 240\* (RGB) \*320,TFT-Panel

Viewing Direction:

Backlight Type: White LED

## 2. MECHANICAL SPECIFICATIONS:

ITEM	SPECIFICATION	UNIT
DISPLAY SIZE	2.0	inch
OUTLINE DIMENSIONS	35.7*51.20*2.40	mm
DRIVER IC	ST7789V	-
INTERFACE TYPE	MCU	-

\*See attached drawing for details.

## 3. BLOCK DIAGRAM:

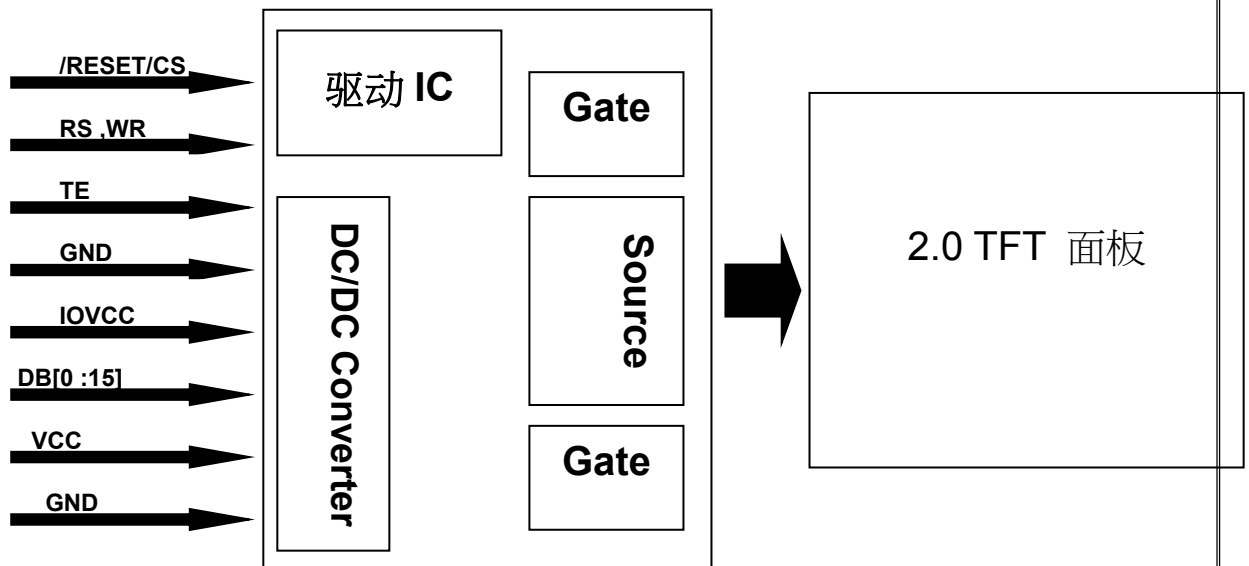

# 4.DIMENSIONAL OUTLINE:

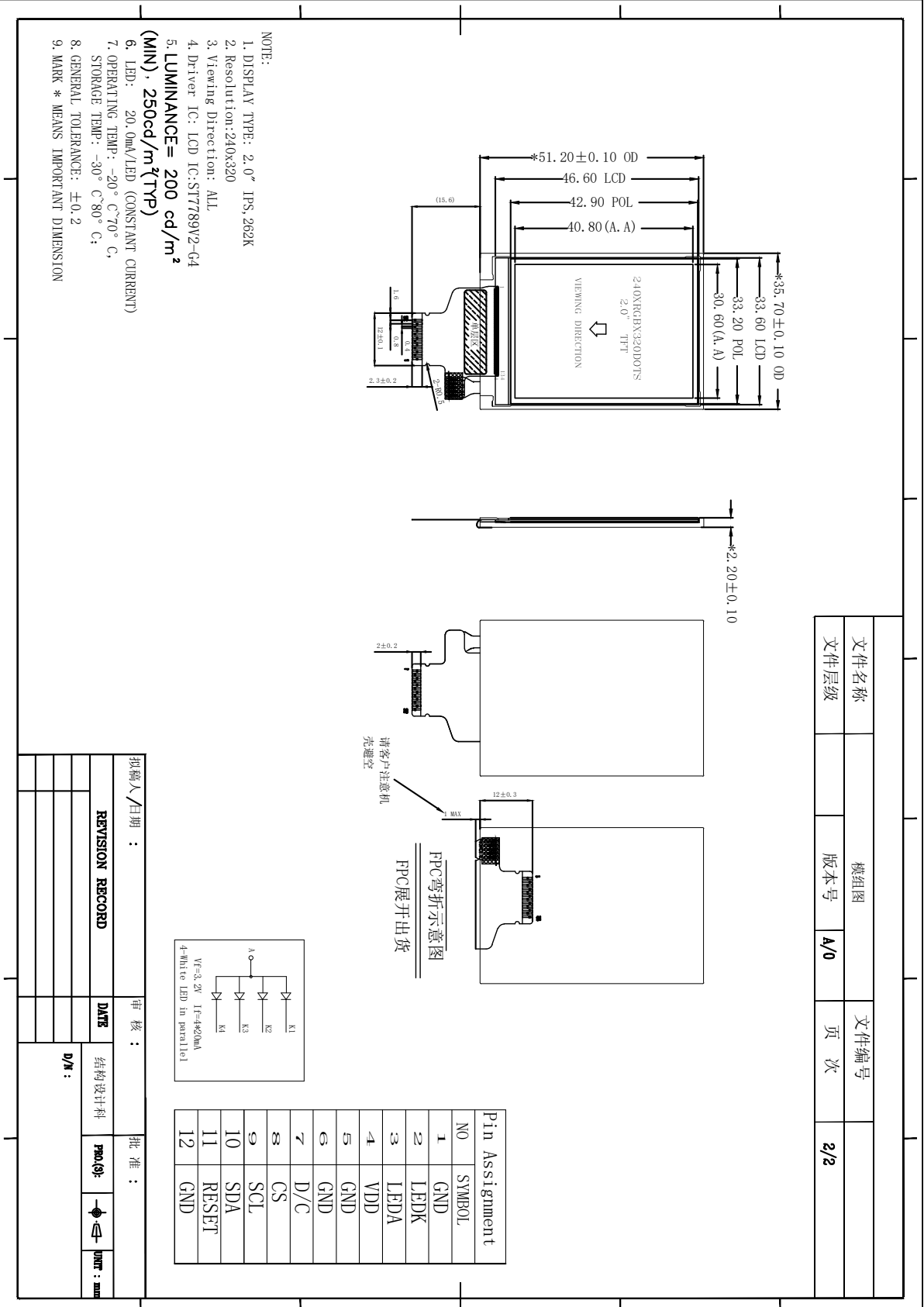

文件名称	模组图	文件编号	
文件层级	版本号	页次	2/2

拟输入/日期 :	审核 :	批准 :
REVISION RECORD	DATE	结构设计科
		PMO(QS)
		INT : mm
		D/M :

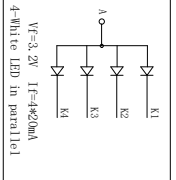

## 6. MAXIMUM ABSOLUTE LIMIT:

Item	Symbol	Value	Unit
Power supply voltage for logic	V <sub>DD</sub>	1.6~3.3	V
Input voltage	V <sub>in</sub>	V <sub>DD</sub> +0.3	V
Operating temperature	T <sub>opr</sub>	-10 to 60	°C
Storage temperature	T <sub>stg</sub>	-20 to 70	°C

**Note:** Note1: Absolute maximum rating is the limit value beyond which the IC maybe broken.

They do not assure operations.

Note2: Background color changes slightly depending on ambient temperature. This Phenomenon is reversible.

T<sub>a</sub> ≤ 60°C: 75%RH max

T<sub>a</sub> > 60°C: absolute humidity must be lower than the humidity of 75%RH at 60°C

Note3: T<sub>a</sub> at -20°C will be <48hrs, at 70 °C will be <120hrs

## 7.ELECTRICAL CHARACTERISTICS

### 7-1 DC Characteristics (V<sub>DD</sub>=2.8V,T<sub>a</sub>=25°C)

Item	Symbol	Min	Type	Max	Unit	Test condition
Operating voltage	V <sub>DD</sub>	2.6	2.8	3.3	V	-
Supply current	I <sub>DD</sub>	-	-	5	mA	V <sub>DD</sub> =2.8V,T <sub>a</sub> =25°C
Input voltage	V <sub>IH</sub>	0.8V <sub>DD</sub>	-	V <sub>DD</sub>	V	-
	V <sub>IL</sub>	0	-	0.2V <sub>DD</sub>	V	
Input leakage current	I <sub>IL</sub>	-1.0	-	1.0	μA	V <sub>IN</sub> =V <sub>DD</sub> or V <sub>SS</sub>

Note: Voltage greater than above may damage the module.

All voltages are specified relative to V<sub>SS</sub>=0V.

### 7-2 Backlight Electrical-optical Characteristics

#### 1. Stander Lamp Styles (Edge Lighting Type):

The LED chips are distributed over the edge light area of the illumination unit, which gives the less power consumption:

#### 2. The Main Advantages of the LED Backlight are as following:

2.1 The brightness of the backlight can simply be adjusted by a resistor or a potentiometer.

#### 3. Data About LED Backlight:

Item	Symbol	MIN	TYP	MAX	UNIT	Test Condition	Note
Supply Voltage	V <sub>f</sub>	3.0	3.2	3.4	V	I <sub>f</sub> =45 mA	-

<b>Supply Current</b>	If	-	<b>40</b>	-	mA	-	-
<b>Reverse Voltage</b>	Vr	-	-	5	V	-	
<b>Power dissipation</b>	Pd	-	288	-	mW	-	
<b>Luminous Intensity for LCM</b>	-	-	250	-	Cd/m <sup>2</sup>	If=45mA	-
<b>Uniformity for LCM</b>	-	80	-	-	%	If=45 mA	-
<b>Backlight Color</b>	White						

**NOTE:**

1. Uniformity = Min/Max \* 100%
2. LED life time defined as follows:  
The final brightness is at 70% of original brightness;  
Measured Method: (X\*Y: Light Area);

**7-3.Touch screen panel specifications:**

Item	Symbol	Min.	Type.	Max.	unit	Remark
Transparency	-	-	82	-	%	JIS K-7105
Haze	-	-	1	-	%	JIS K-7105
Hardness Of Surface	-	-	3	-	H	150gf 45°
FPC Peeling Strength	-	5		-	N	Upward 90°
FPC Bending	-	-	3	-	cycle	R=1.0, 90°
Input Force	-	-		50	gf	-
Rated Voltage	V touch			7	V	DC
X-axis Resistance	Rx	150		500		FPC PIN
X-axis Resistance	Ry	200		800		
Linearity	-	-	±1.5	±2.0	%	-
Chattering	-	-	-	20	ms	-
Insulation Resistance	Ri	10	-	-	MΩ	-
Notes Life	-	1,00,000	-	-	Times	-
Input Life	-	1,00,000	-	-	Times	-

## 8. AC CHARACTERISTICS ( $V_{DD}=2.8V, T_A=25^\circ C$ )

### 8.1. Interface : System Bus Read/Write Characteristics.

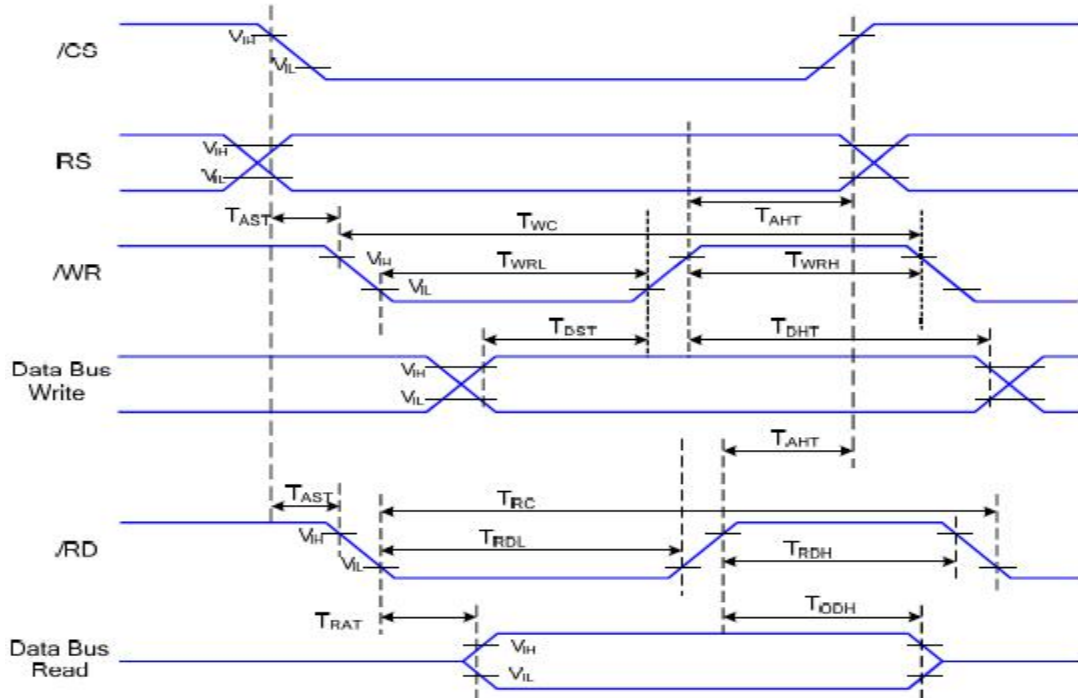

Signal	Symbol	Parameter	Min	Max	Unit	Description
RS	$T_{AST}$	Address Setup Time	10	-	ns	
	$T_{AHT}$	Address Hold Time (Write/Read)	5	-	ns	
/WR	$T_{WC}$	Write Cycle	100	-	ns	
	$T_{WRH}$	Control Pulse "H" Duration	50	-	ns	
	$T_{WRL}$	Control Pulse "L" Duration	50	-	ns	
/RD	$T_{RC}$	Read Cycle	300	-	ns	
	$T_{RDH}$	Control Pulse "H" Duration	150	-	ns	
	$T_{RDL}$	Control Pulse "L" Duration	150	-	ns	
DB[17:0]	$T_{DST}$	Data Setup Time	10	-	ns	$T_{RAT}, T_{RATFM}$ : 3K ohm Pullup or Down and 30pF Parallel Cap. To GND. $T_{ODH}$ : 3K ohm Pullup or Down.
	$T_{DHT}$	Data Hold Time	15	-	ns	
	$T_{RAT}$	Read Access Time	-	100	ns	
	$T_{ODH}$	Output Disable Time	50	-	ns	



## 9. OPTICAL CHARACTERISTICS:

No.	ITEM		Symbol	Conditions	Specification			Unit	Note
					Min	Typ	Max		
1	Response Time		Tr+Tf	25°C	-	15	-	Ms	(1)(2)
2	Transmittance (With PL)		T(%)	-	-	7.1	-	-	-
3	Contrast Rate		Cr	$\theta=0$ , Normal viewing angle	-	250	-	-	(1)(3)
4	Viewing Angle	Hor.	$\theta R$	CR>45	-	80	-	Deg	-
			$\theta L$		-	80	-		
		Ver.	$\Theta+$		-	80	-		
			$\Theta-$		-	80	-		

Measure Conditions:

1. Measure surrounding : dark room;
2. Ambient temperature:  $25\pm 2^\circ\text{C}$ ;
3. 30min.warm-up time.

### Note Definition:

Note(1)Viewing angle range:

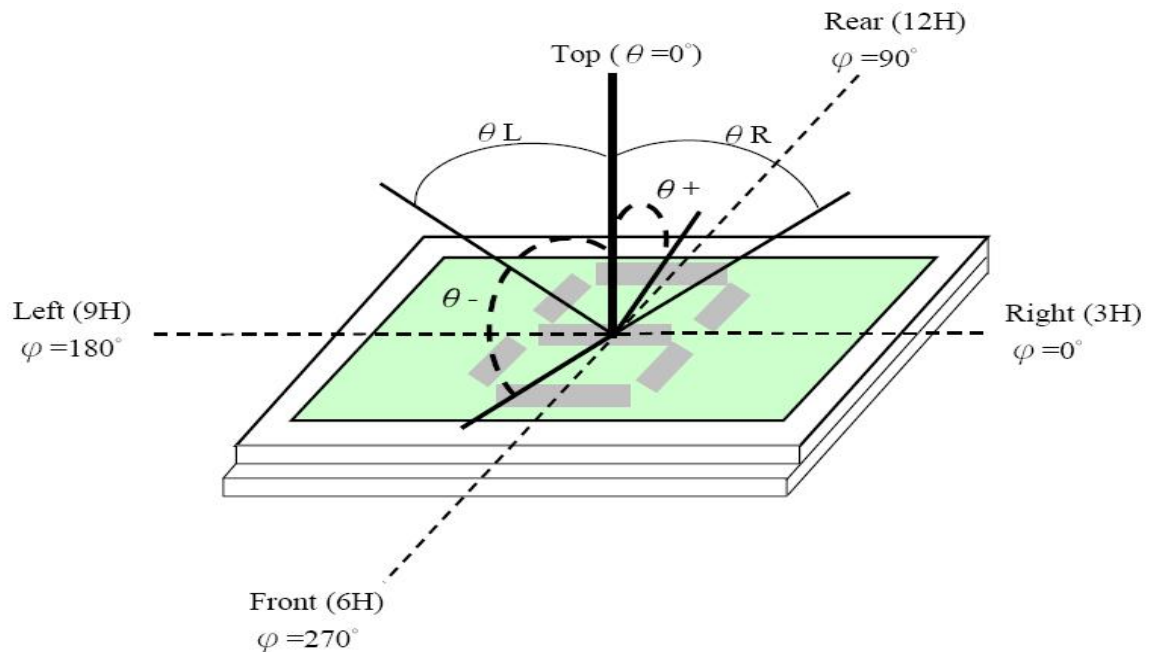

Note (2)Response Time:

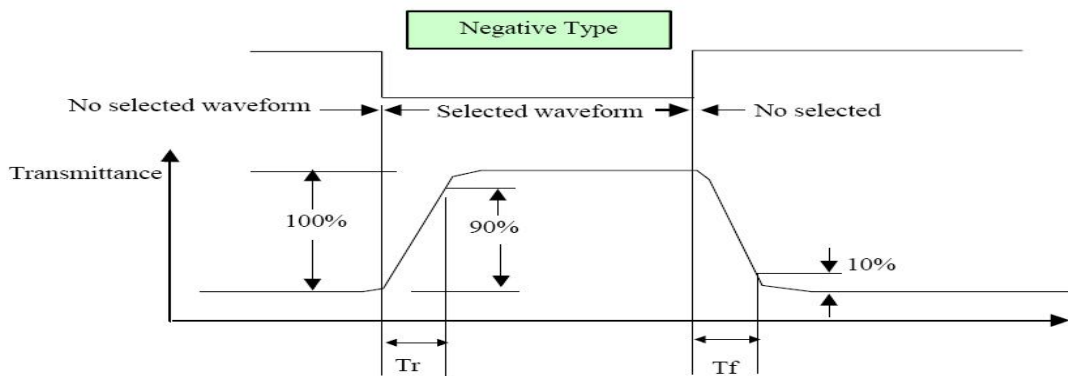
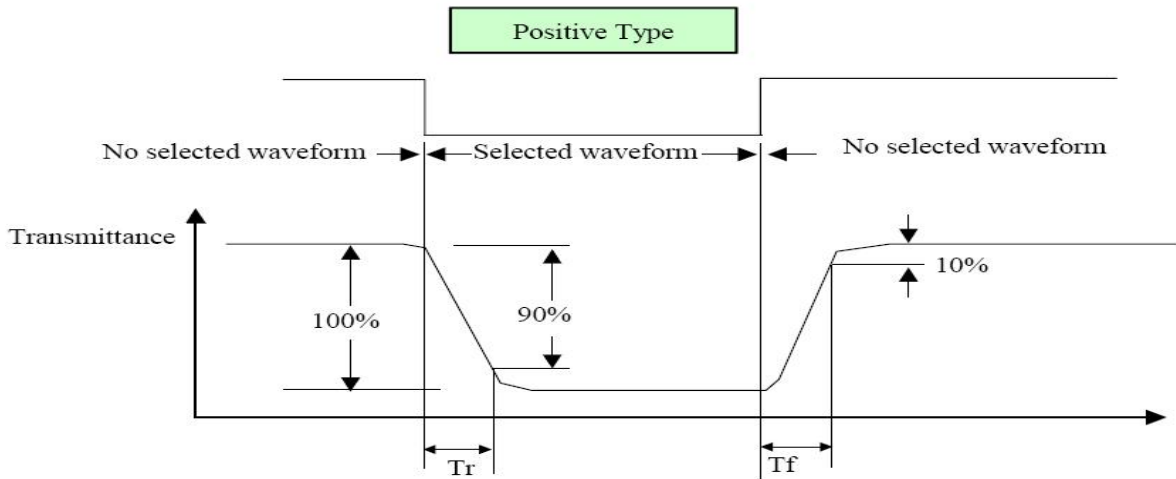

**Note(3) Contrast Ratio Definition:**

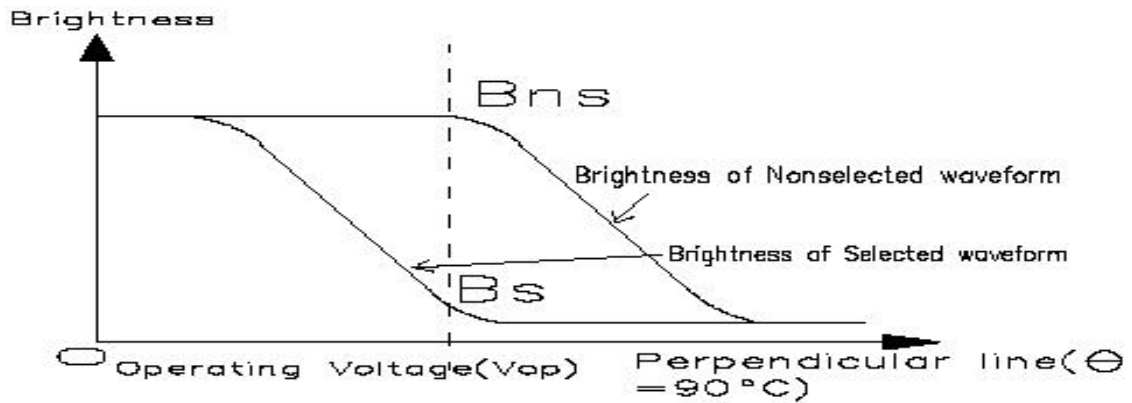

**Luminance with all pixel white**

**Contrast Ratio (Cr) =** \_\_\_\_\_

**Luminance with all pixel black**

# 10.PACKAGE.

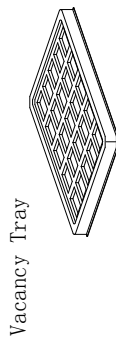

+

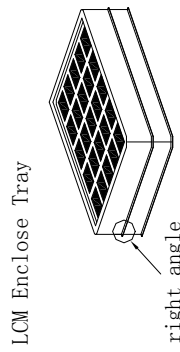

⇒

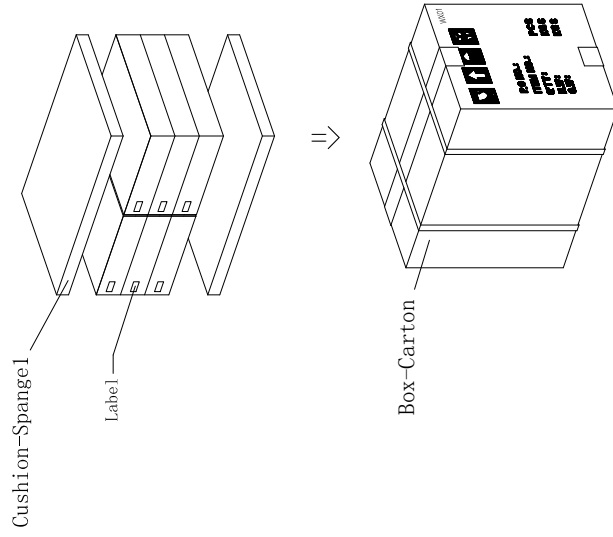
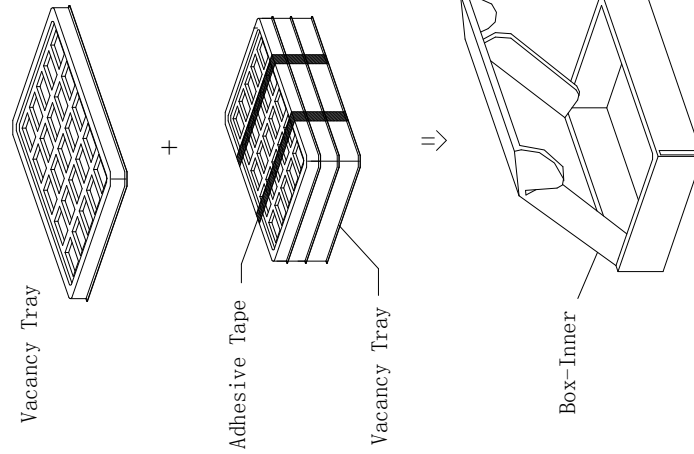
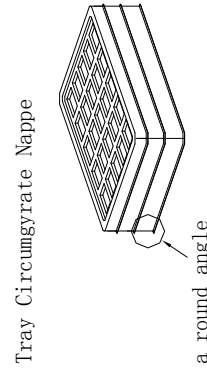

NOTE:

1. PET Tray Nappe Circumgyrate 180°
2. LCM Panel Packaging Heads

## **11. STANDARD SPECIFICATION FOR RELIABILITY:**

Item	Condition	Time (hrs)	Assessment
High temp. Storage	70°C	120	No abnormalities in functions and appearance
High temp. Operating	60°C	120	
Low temp. Storage	-20°C	120	
Low temp. Operating	-10°C	120	
Humidity	40°C/ 90%RH	120	
Thermal Shock Temp. Cycle	-10°C ← 25°C →60°C (0.5 hour ← 5 min → 0.5 hour)	10cycles	

Functions, performance, appearance, etc. shall be free from remarkable deterioration within 50,000 hours under ordinary operating and storage conditions room temperature (25±10°C), normal humidity (45±20% RH), and in area not exposed to direct sun light. (Life time of backlight, please refer to Data about backlight.)

### **Testing Conditions and Inspection Criteria:**

For the final test the testing sample must be stored at room temperature for 24 hours, after the tests listed in up Table, Standard specifications for Reliability have been executed in order to ensure stability.

Item	Test Model	In section Criteria
Current Consumption	Refer To Specification	The current consumption should conform to the product specification.
Contrast	Refer To Specification	After the tests have been executed, the contrast must be larger than half of its initial value prior to the tests.
Appearance	Visual inspection	Defect free.

## **12.SPECIFICATION OF QUALITY ASSURANCE:**

### **12.1 Purpose**

This standard for Quality Assurance should affirm the quality of LCD Module products to supply to purchaser by Saef Technology Limited.

### **12.2 Standard for Quality Test**

#### a. Inspection:

Before delivering, the supplier should take the following tests, and affirm the quality of product.

#### b. Electro-Optical Characteristics:

According to the individual specification to test the product.

#### c. Test of Appearance Characteristics:

According to the individual specification to test the product.

#### d. Test of Reliability Characteristics:

According to the definition of reliability on the specification for testing products.

#### e. Delivery Test:

Before delivering, the supplier should take the delivery test.

(i) Test method: According to MIL-STD105E.General Inspection Level II take a single time.

(ii) The defects classify of AQL as following:

Major defect: AQL = 0.65

Minor defect: AQL = 2.5

Total defects: AQL = 2.5

### **12-3. Nonconforming Analysis & Deal With Manners**

#### a. Nonconforming Analysis:

(i) Purchaser should supply the detail data of non- conforming sample and the non- conforming.

(ii) After accepting the detail data from purchaser, the analysis of nonconforming should be finished in two weeks.

(iii) If supplier can not finish analysis on time, must announce purchaser before two weeks.

#### b. Disposition of nonconforming:

(i) If find any product defect of supplier during assembly time, supplier must change the good product for every defect after recognition.

(ii) Both supplier and customer should analyze the reason and discuss the disposition of nonconforming when the reason of nonconforming is not sure.

### **12-4. Agreement items**

Both sides should discuss together when the following problems happen.

a. There is any problem of standard of quality assurance, and both sides think that it must be modified.

b. There is any argument item which does not record in the standard of quality assurance.

c. Any other special problem.

### **12-5 Standard of The Product Appearance Test**

a. Manner of appearance test: This specification should be applied for both light on and off situation.

(i) The test must be under 20W × 2 or 40W fluorescent light, and the distance of view must

be at  $30 \pm 5$ cm.

(ii) When test the model of transmissive product must add the reflective plate.

(iii)The test direction is base on about around  $10^\circ$  of vertical line (Left graph)

(iii)Temperature:  $25 \pm 5^\circ\text{C}$  Humidity:  $65 \pm 10\%RH$

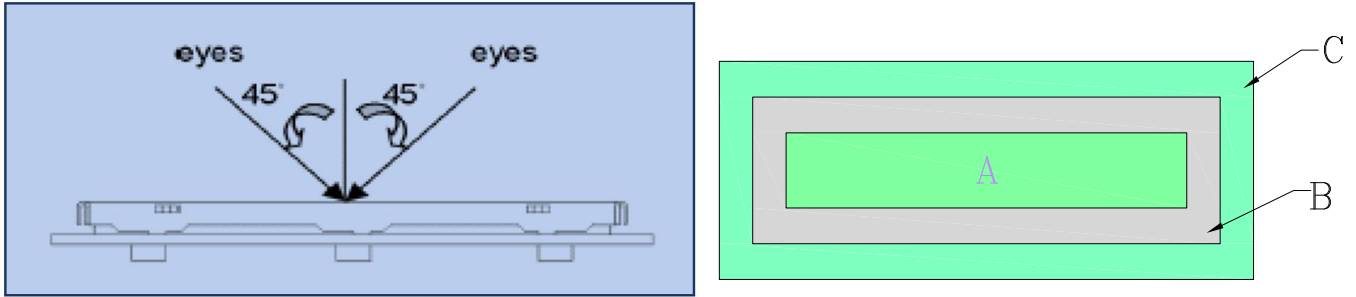

(iv) Definition of area (Right graph)

A. Area: Viewing area.      B. Area: Out of viewing area.(Outside viewing area)

b. Basic principle:

(i) It will accord to the AQL when the standard can not be described.

(ii) The sample of the lowest acceptable quality level must be discussed by both supplier and customer when any dispute happened.

(iii) Must add new item on time when it is necessary.

c. Standard of inspection: (Unit: mm)

Allowable limits defined in follow Dot defect Table should be met for each white, black , R, G, B raster. The limits apply to the entire area. Missing white in 60% or more of typical (one color, R or G or B) pixel aperture is defined as a bright defect, less than 60% is acceptable .Black spot in 60% or more of typical pixel aperture is defined as a dark defect, less than 60% is acceptable.

Dot defect table:

Item		White dot defect	Black dot defect	Total
1	Defect counts	3	3	3
2	Combined defect Counts	No combined dot defect allowed. Two Single dot defect that within 5mm during each dot defect should be counted as combined dot defect.		

## 12-6 Inspection specification

AQL inspection standard

Sampling method: MIL-STD-105E, Level II, single sampling

Classify	Item		Note	AQL
<b>Major</b>	Display state	Short or open circuit	1	0.65
		Contrast defect (dim, ghost)		
		LC leakage		
		Flickering		
		No display		
		Wrong viewing direction	2	
		Wrong Back-light	7	
	Non-display	Flat cable or pin reverse	9	
		Wrong or missing component	10	
<b>Minor</b>	Display state	Background color deviation	2	2.5
		Black spot and dust	3	
		Line defect	4	
		Scratch		
		Rainbow	5	
		Pin hole	6	
	Polarizer	Bubble and foreign material	3	
		Scratch	4	
	PCB,FPC	Scratch	4	
	Soldering	Poor connection	8	
	Wire	Poor connection	9	
	LCD	CHIP OUT	11	

**Note on defect classification :**

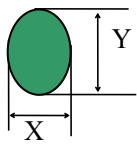
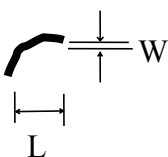
No.	Item	Criterion																	
1	Short or open circuit	Not allow																	
	LC leakage																		
	Flickering																		
	No display																		
	Wrong viewing direction																		
	Wrong Back-light																		
2	Contrast defect	Refer to approval sample																	
	Background color deviation																		
3	<p>Point defect, Black spot, dust (incl. Polarizer) ex.: dirt under polarizer, Pinhole of reflector ,glass scratch, dirt under glass,scratch on polarizer <math>\phi = (X+Y)/2</math></p>  <table border="1" data-bbox="901 929 1340 1220"> <thead> <tr> <th>Point Size</th> <th>Acceptable Qty.</th> </tr> </thead> <tbody> <tr> <td><math>\phi \leq 0.10</math></td> <td>Disregard</td> </tr> <tr> <td><math>0.10 &lt; \phi \leq 0.20</math></td> <td>3</td> </tr> <tr> <td><math>0.20 &lt; \phi \leq 0.25</math></td> <td>2</td> </tr> <tr> <td><math>0.25 &lt; \phi \leq 0.30</math></td> <td>1</td> </tr> <tr> <td><math>\phi &gt; 0.30</math></td> <td>0</td> </tr> </tbody> </table> <p style="text-align: right;">Unit: mm</p>	Point Size	Acceptable Qty.	$\phi \leq 0.10$	Disregard	$0.10 < \phi \leq 0.20$	3	$0.20 < \phi \leq 0.25$	2	$0.25 < \phi \leq 0.30$	1	$\phi > 0.30$	0						
Point Size	Acceptable Qty.																		
$\phi \leq 0.10$	Disregard																		
$0.10 < \phi \leq 0.20$	3																		
$0.20 < \phi \leq 0.25$	2																		
$0.25 < \phi \leq 0.30$	1																		
$\phi > 0.30$	0																		
4	<p>Line defect</p>  <table border="1" data-bbox="885 1444 1428 1691"> <thead> <tr> <th>L</th> <th>Line W</th> <th>Acceptable Qty.</th> </tr> </thead> <tbody> <tr> <td>---</td> <td><math>0.015 \geq W</math></td> <td>Disregard</td> </tr> <tr> <td><math>3.0 \geq L</math></td> <td><math>0.03 \geq W</math></td> <td rowspan="2">2</td> </tr> <tr> <td><math>2.0 \geq L</math></td> <td><math>0.05 \geq W</math></td> </tr> <tr> <td><math>1.0 \geq L</math></td> <td><math>0.1 &gt; W</math></td> <td>1</td> </tr> <tr> <td>---</td> <td><math>0.05 &lt; W</math></td> <td>Applied as point defect</td> </tr> </tbody> </table> <p style="text-align: right;">Unit: mm</p>	L	Line W	Acceptable Qty.	---	$0.015 \geq W$	Disregard	$3.0 \geq L$	$0.03 \geq W$	2	$2.0 \geq L$	$0.05 \geq W$	$1.0 \geq L$	$0.1 > W$	1	---	$0.05 < W$	Applied as point defect	
L	Line W	Acceptable Qty.																	
---	$0.015 \geq W$	Disregard																	
$3.0 \geq L$	$0.03 \geq W$	2																	
$2.0 \geq L$	$0.05 \geq W$																		
$1.0 \geq L$	$0.1 > W$	1																	
---	$0.05 < W$	Applied as point defect																	
5	Rainbow	Not more than two color changes across the viewing area																	
No.	Item	Criterion																	
6	Segment pattern	(1) Pin hole																	



Point Size	Acceptable Qty
------------	----------------

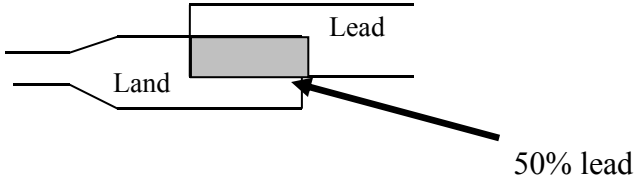

	<b>W = Segment width</b> $\phi = (X+Y)/2$	$\phi < 0.15\text{mm}$ is acceptable.
7	<b>Back-light</b>	(1) The color of backlight should correspond its specification. (2) Not allow flickering
8	<b>Soldering</b>	(1) Not allow heavy dirty and solder ball on PCB or FPC. (The size of dirty refer to point and dust defect) (2) Over 50% of lead should be soldered on Land. 
9	<b>Wire</b>	(1) Copper wire should not be rusted (2) Not allow crack on copper wire connection. (3) Not allow reversing the position of the flat cable. (4) Not allow exposed copper wire inside the flat cable.
10	<b>PCB,FPC</b>	(1) Not allow screw rust or damage. (2) Not allow missing or wrong putting of component.

**2.1.1 chip on the surface**

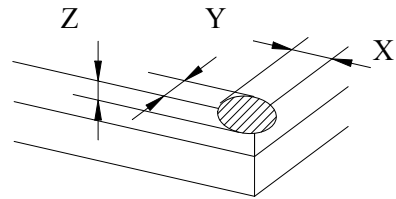
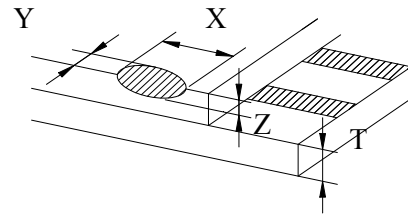
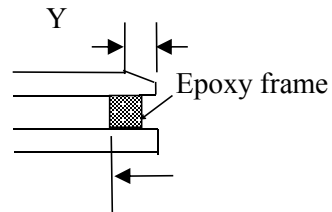
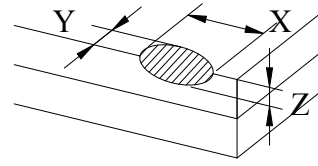

Note: A:LCD Length

LCD

11

X	Y	Z
$>1/8A$	$\leq 0.3\text{mm}$	$\leq 1/2T$
$\leq 1/8A$	Not enter into epoxy frame	$\leq T$
	Not enter into the inner edge of epoxy	$\leq 1/2T$

11

LCD

**2.1.2 chip on the terminal**

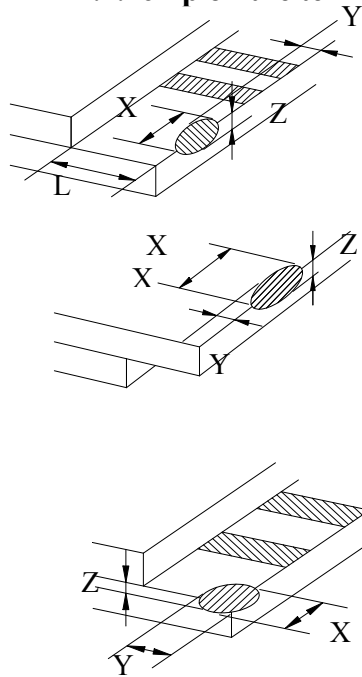

X	Y	Z
$>1/8A$	$\leq 0.3\text{mm}$	$\leq 1/2T$
$\leq 1/8A$	$\leq 1/2L$	$\leq T$
$\leq 1/8A \& \leq 1\text{mm}$	$\leq L$	$\leq T$
$\leq 1/8A \& \leq 2\text{mm}$	$\leq L$	$\leq 1/2T$

Note: A:LCD Length.

the distance between crack and contact pad must be greater than the width of 1<sup>st</sup> contact pad.

**2.1.3 chip out on between side**

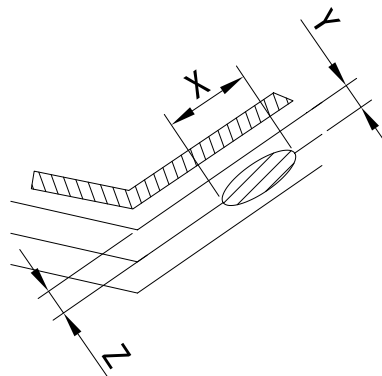

11

LCD

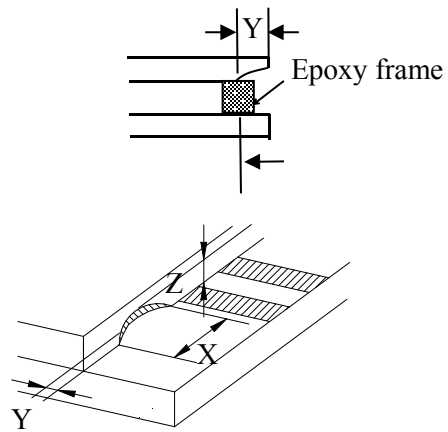

X	Y	Z
$\leq 1/8A$	Not enter into epoxy frame	$Z \leq 2T$
	Not enter into 1/2 epoxy frame	$Z \leq 1/2T$

Note: A : LCD Length

2.1.4 including corner chip and side chip

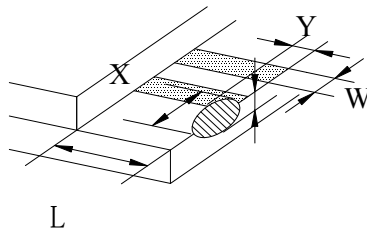

Note: A:LCD Length

X	Y	Z
$>1/8A$	$\leq 1/6L$	$\leq 1/2T$
$\leq 1/8A$	$\leq 1/3L$	
$\leq 1/4W$	$\leq 2/3L$	

**2.2 Chip out**

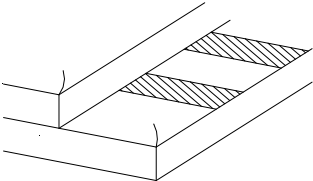

1) Chip out is that crackles extend to inner edge.  
 2) Crackles round epoxy frame will be rejected.  
 3) Chip out on the terminal will be rejected:  $Z=T$  length  $>1\text{mm}$  or  $Z<T$  length  $>2\text{mm}$   
 4) The chip out at ITO will be rejected.

**2.3 Poor cutting**

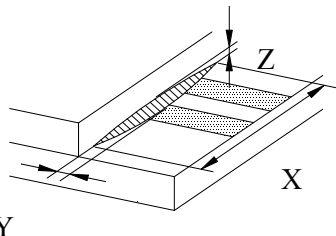

X	Y	Z
$>1/8$ A	$\leq 0.3$	$\leq 1/2T$
$\leq 1/8$ A	According to drawing	$1/2T \leq Z \leq T$

**Note : A:**  
LCD Length.

**12**                      **SMT**

According to the <Acceptable of electronic assemblies> IPC-A-610C class 2 stander. Component missing or function defect are Major defect ,the others are Minor defect.

**Any one out of the specification will be rejected.**

## **13. GENERAL PRECAUTIONS**

### (1) Mounting Method

The panel of the LCD Module consists of two thin glass plates with polarizers which easily get damaged since the Module is fixed by utilizing fitting holes in the printed circuit board. Extreme care should be taken when handling the LCD Modules.

### (2) Caution of LCD handling & cleaning

When cleaning the display surface, use soft cloth with solvent (recommended below) and wipe lightly.

- Isopropyl alcohol
- Ethyl alcohol
- Trichlorotrifluoroethane

Do not wipe the display surface with dry or hard materials that will damage the polarizer surface. Do not use the following solvent:

- Water
- Ketone
- Aromatics

### (3) Caution against static charge

The LCD Module use C-MOS LSI drivers, so we recommend that you connect any unused input terminal to VDD or VSS, do not input any signals before power is turned on. And ground your body, Work/assembly table. And assembly equipment to protect against static electricity.

### (4) Packaging

Modules use LCD elements, and must be treated as such. Avoid intense shock and falls from a height.

- To prevent modules from degradation. Do not operate or store them exposed directly to sunshine or high temperature/humidity.

### (5) Caution for operation

- It is indispensable to drive LCD's within the specified voltage limit since the higher voltage than the limit shorten LCD life. An electrochemical reaction due to direct current causes LCD deterioration, Avoid the use of direct current drive.
- Response time will be extremely delayed at lower temperature than the operating temperature range and on the other hand at higher temperature LCD's show dark color in them.

However those phenomena do not mean malfunction or out of order with LCD's which will come back in the specified operating temperature range.

- If the display area is pushed hard during operation, some font will be abnormally displayed but it resumes normal condition after turning off once.
- As light dew depositing on terminals is a cause for electro-chemical reaction resulting in terminal

open circuit.

Usage under the relative condition of 40°C, 50%RH or less is required.

(6) Storage

In the case of storing for a long period of time (for instance, for years) for the purpose or replacement use, The following ways are recommended.

- Storage in a polyethylene bag with sealed so as not to enter fresh air outside in it, And with no desiccant.
- Placing in a dark place where neither exposure to direct sunlight nor light is.

Keeping temperature in the specified storage temperature range.

- Storing with no touch on polarizer surface by the anything else. (It is recommended to store them as they have been contained in the inner container at the time of delivery)

(7) Safety

- It is recommendable to crash damaged or unnecessary LCD into pieces and wash off liquid crystal by using solvents such as acetone and ethanol which should be burned up later.
- When any liquid crystal leaked out of a damaged glass cell comes in contact with your hands, please wash it off well with soap and water.

**- END -**