SPECIFICATION

Product Model: YX240QV29-T (Rev.A)

Designed by	R&D Checked by	Quality Department by	Approved by

Approval by Customer

<p>OK</p> <p>NG, Problem survey:</p> <p style="text-align: right;">Approved By _____</p>
--

Revision Record

REV NO.	REV DATE	CONTENTS	Note
A	2014-12-02	NEW ISSUE	

Table Of Contents

List	Description	Page No.
	Cover	1
	Revision Record	2
	Table Of Contents	3
1	Numbering System	4
2	General Information	4
3	External Dimensions	5
4	Interface Description	6
5	Absolute Maximum Ratings	7
6	Electrical Characteristics	7
7	Timing Characteristics	8
8	Backlight Characteristics	11
9	Optical Characteristics	11
10	Reliability Test Conditions And Methods	13
11	Inspection Standard	14
12	Handling Precautions	17
13	Precaution For Use	18
14	Packing Method	18

1. Numbering System

2. General Information

ITEM	STANDARD VALUES	UNITS
LCD type	2.4" TFT	--
Dot arrangement	240(RGB) × 320	dots
Color filter array	RGB vertical stripe	--
Display mode	TN / Transmission / Normally White	--
Viewing Direction	6 o'clock	--
Driver IC	ILI9341	--
Module size	42.72(W) × 60.26(H) × 3.5(T)	mm
Active area	36.72(W) × 48.96(H)	mm
Dot pitch	0.153 (W) × 0.153 (H)	mm
Interface	4-lines_8bit / 3-lines_9bit SPI 8-/ 9-/16-/18-bit 8080-series system interface 6-/16-/18-bit RGB interface	--
Operating temperature	-20 ~ +70	°C
Storage temperature	-30 ~ +80	°C
Back Light	4 White LED In Parallel	--
Weight	TBD	g

3. External Dimensions

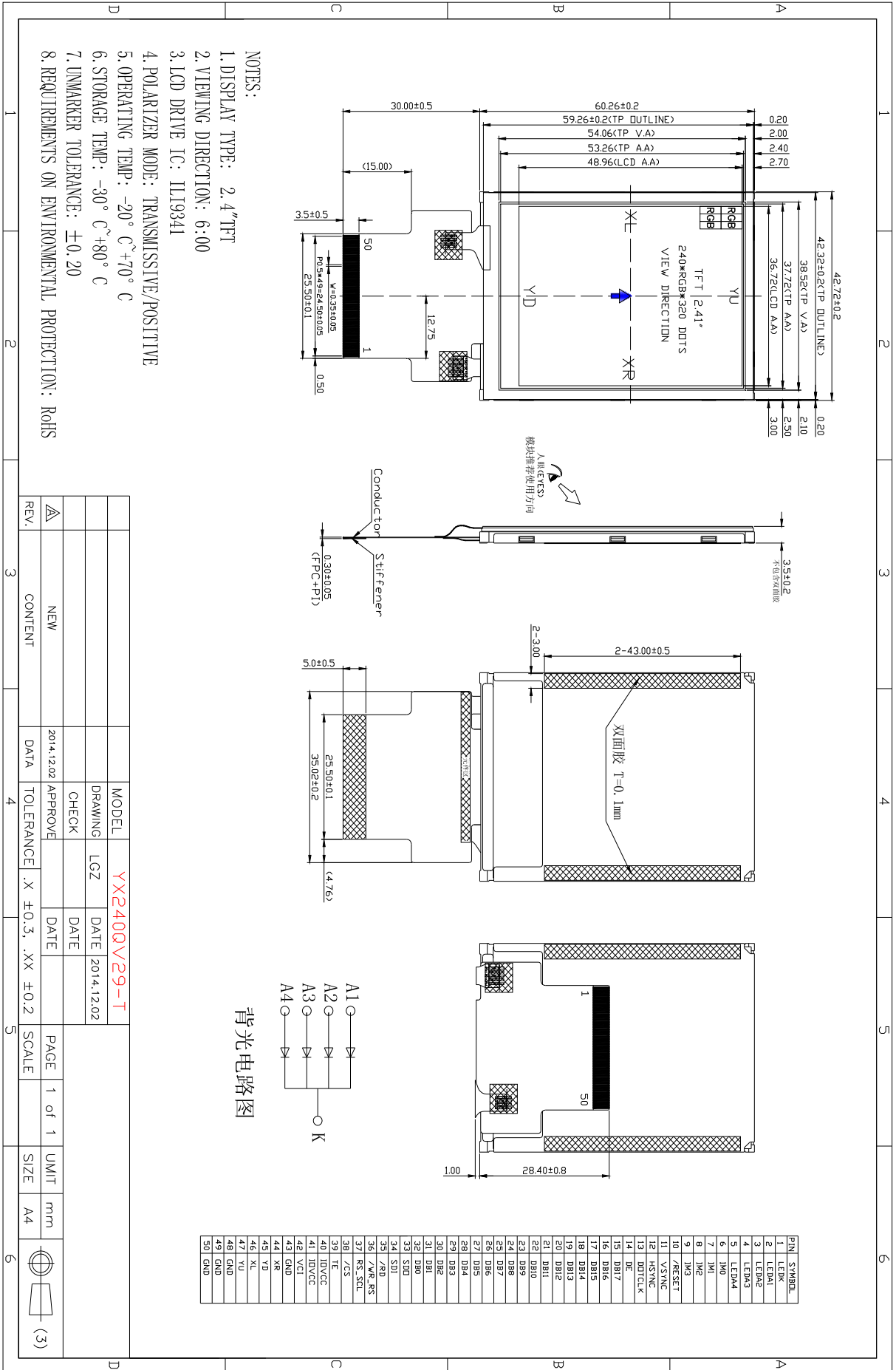

4. Interface Description

Pin	Symbol	Description.																																																																														
1	LEDK	LED backlight (Cathode).																																																																														
2	LEDA1	LED backlight (Anode).																																																																														
3	LEDA2	LED backlight (Anode).																																																																														
4	LEDA3	LED backlight (Anode).																																																																														
5	LEDA4	LED backlight (Anode).																																																																														
6	IM0	System interface Mode																																																																														
		<table border="1"> <thead> <tr> <th>IM3</th> <th>IM2</th> <th>IM1</th> <th>IM0</th> <th>Interface mode</th> <th>DB Pin</th> </tr> </thead> <tbody> <tr> <td>0</td> <td>0</td> <td>0</td> <td>0</td> <td>i80-system 8-bit interface I</td> <td>DB[7:0]</td> </tr> <tr> <td>0</td> <td>0</td> <td>0</td> <td>1</td> <td>i80-system 16-bit interface I</td> <td>DB[15:0]</td> </tr> <tr> <td>0</td> <td>0</td> <td>1</td> <td>0</td> <td>i80-system 9-bit interface I</td> <td>DB[8:0]</td> </tr> <tr> <td>0</td> <td>0</td> <td>1</td> <td>1</td> <td>i80-system 18-bit interface I</td> <td>DB[17:0]</td> </tr> <tr> <td>0</td> <td>1</td> <td>0</td> <td>1</td> <td>3-wires_9-bit SPI I</td> <td>/CS,SDI,SCL</td> </tr> <tr> <td>0</td> <td>1</td> <td>1</td> <td>0</td> <td>4-wires_8-bit SPI I</td> <td>/CS,RS,SDI,SCL</td> </tr> <tr> <td>1</td> <td>0</td> <td>0</td> <td>0</td> <td>i80-system 16-bit interface II</td> <td>DB[17:10],DB[8:1]</td> </tr> <tr> <td>1</td> <td>0</td> <td>0</td> <td>1</td> <td>i80-system 8-bit interface II</td> <td>DB[17:10]</td> </tr> <tr> <td>1</td> <td>0</td> <td>1</td> <td>0</td> <td>i80-system 18-bit interface II</td> <td>DB[17:0]</td> </tr> <tr> <td>1</td> <td>0</td> <td>1</td> <td>1</td> <td>i80-system 9-bit interface II</td> <td>DB[17:9]</td> </tr> <tr> <td>1</td> <td>1</td> <td>0</td> <td>1</td> <td>3-wires_9-bit SPI II</td> <td>/CS,SDI,SDO,SCL</td> </tr> <tr> <td>1</td> <td>1</td> <td>1</td> <td>0</td> <td>4-wires_8-bit SPI II</td> <td>/CS,RS,SDI,SDO,SCL</td> </tr> </tbody> </table>	IM3	IM2	IM1	IM0	Interface mode	DB Pin	0	0	0	0	i80-system 8-bit interface I	DB[7:0]	0	0	0	1	i80-system 16-bit interface I	DB[15:0]	0	0	1	0	i80-system 9-bit interface I	DB[8:0]	0	0	1	1	i80-system 18-bit interface I	DB[17:0]	0	1	0	1	3-wires_9-bit SPI I	/CS,SDI,SCL	0	1	1	0	4-wires_8-bit SPI I	/CS,RS,SDI,SCL	1	0	0	0	i80-system 16-bit interface II	DB[17:10],DB[8:1]	1	0	0	1	i80-system 8-bit interface II	DB[17:10]	1	0	1	0	i80-system 18-bit interface II	DB[17:0]	1	0	1	1	i80-system 9-bit interface II	DB[17:9]	1	1	0	1	3-wires_9-bit SPI II	/CS,SDI,SDO,SCL	1	1	1	0	4-wires_8-bit SPI II	/CS,RS,SDI,SDO,SCL
IM3	IM2	IM1	IM0	Interface mode	DB Pin																																																																											
0	0	0	0	i80-system 8-bit interface I	DB[7:0]																																																																											
0	0	0	1	i80-system 16-bit interface I	DB[15:0]																																																																											
0	0	1	0	i80-system 9-bit interface I	DB[8:0]																																																																											
0	0	1	1	i80-system 18-bit interface I	DB[17:0]																																																																											
0	1	0	1	3-wires_9-bit SPI I	/CS,SDI,SCL																																																																											
0	1	1	0	4-wires_8-bit SPI I	/CS,RS,SDI,SCL																																																																											
1	0	0	0	i80-system 16-bit interface II	DB[17:10],DB[8:1]																																																																											
1	0	0	1	i80-system 8-bit interface II	DB[17:10]																																																																											
1	0	1	0	i80-system 18-bit interface II	DB[17:0]																																																																											
1	0	1	1	i80-system 9-bit interface II	DB[17:9]																																																																											
1	1	0	1	3-wires_9-bit SPI II	/CS,SDI,SDO,SCL																																																																											
1	1	1	0	4-wires_8-bit SPI II	/CS,RS,SDI,SDO,SCL																																																																											
7	IM1																																																																															
8	IM2																																																																															
9	IM3																																																																															
10	/RESET	Reset input pin, Active "L".																																																																														
11	VSYNC	Vertical sync signal in RGB I/F.																																																																														
12	HSYNC	Horizontal sync signal in RGB I/F.																																																																														
13	DOTCLK	Pixel clock signal in RGB I/F.																																																																														
14	DE	Data enable signal in RGB I/F mode																																																																														
15	DB17	16-bit parallel bi-directional data bus for MPU- I system: 8-bit I/F: DB[7:0] is used. 9-bit I/F: DB[8:0] is used. 16-bit I/F: DB[15:0] is used. 18-bit I/F: DB[17:0] is used.																																																																														
16	DB16																																																																															
17	DB15																																																																															
18	DB14																																																																															
19	DB13																																																																															
20	DB12																																																																															
21	DB11																																																																															
22	DB10	18-bit parallel bi-directional data bus for MPU- II system: 8-bit I/F: DB[17:10] is used. 9-bit I/F: DB[17:9] is used. 16-bit I/F: DB[17:10] and DB[8:1] is used. 18-bit I/F: DB[17:0] is used.																																																																														
23	DB9																																																																															
24	DB8																																																																															
25	DB7																																																																															
26	DB6	18-bit input data bus for RGB I/F. 6-bit/pixel: DB[5:0] is used; 16-bit/pixel: DB[17:13]=R[4:0], DB[11:6]=G[5:0] and DB[5:1]=B[4:0]; 18-bit/pixel: DB[17:12]=R[5:0], DB[11:6]=G[5:0] and DB[5:0]=B[5:0]; Connect unused pins to GND.																																																																														
27	DB5																																																																															
28	DB4																																																																															
29	DB3																																																																															
30	DB2																																																																															
31	DB1																																																																															
32	DB0																																																																															
33	SDO	Serial output signal in SPI I/F.																																																																														

34	SDI	Serial input signal in SPI I/F.
35	/RD	Reads strobe signal to write data when /RD is "Low" in MPU interface.
36	/WR_RS	MCU: Serves as a write signal and writes data at the rising edge. 4-line SPI: Serves as command or parameter select.
37	RS_SCL	Display data / command selection in 80-series MPU I/F. RS = "0" : Command RS = "1" : Display data. SPI: This pin is used serial interface clock in SPI.
38	/CS	Chip select input pin ("Low" enable) in MPU I/F and SPI I/F.
39	TE	Tearing effect output pin to synchronize MPU to frame writing.
40	IOVCC	I/O power supply.
41	IOVCC	I/O power supply.
42	VCI	System power supply.
43	GND	Power ground
44	XR	TOUCH PIN.
45	YD	
46	XL	
47	YU	
48	GND	
48	GND	Power ground
49	GND	Power ground
50	GND	Power ground

5. Absolute Maximum Ratings

Item	Symbol	Min.	Max.	Unit
Logic Supply Voltage	IOVCC	-0.3	4.6	V
Analog Supply Voltage	VCI	-0.3	4.6	V
Input Voltage	V _{in}	-0.3	IOVCC+0.3	V
Operating Temperature	T _{OP}	-20	70	°C
Storage Temperature	T _{ST}	-30	80	°C
Storage Humidity	HD	20	90	%RH

6. DC Characteristics

Item	Symbol	Min.	Typ.	Max.	Unit	Remark
Logic Supply Voltage	IOVCC	1.65	1.8/2.8	3.3	V	-
Analog Supply Voltage	VCI	2.5	2.8	3.3	V	-
Input High Voltage	V _{IH}	0.7IOVCC	-	IOVCC	V	Digital input pins
Input Low Voltage	V _{IL}	GND	-	0.3IOVCC	V	Digital input pins
Output High Voltage	V _{OH}	0.8IOVCC	-	IOVCC	V	Digital output pins
Output Low Voltage	V _{OL}	GND	-	0.2IOVCC	V	Digital output pins
I/O Leak Current	I _{LI}	-0.1	-	0.1	uA	-

7. Timing Characteristics

7.1 Reset Timing Characteristics

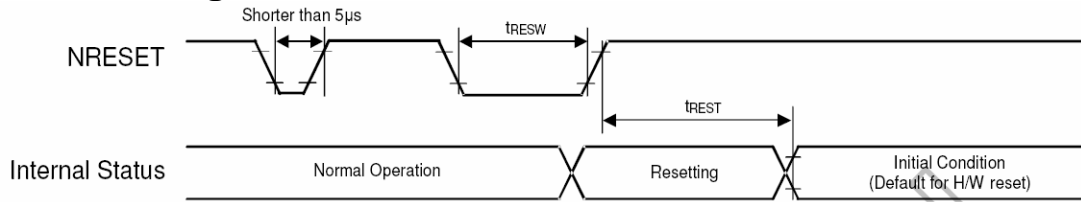

Symbol	Parameter	Related Pins	Spec.			Note	Unit
			Min.	Typ.	Max.		
tRESW	Reset low pulse width ⁽¹⁾	NRESET	10	-	-	-	µs
tREST	Reset complete time ⁽²⁾	-	5	-	-	When reset applied during SLPIN mode	ms
		-	120	-	-	When reset applied during SLPOUT mode	ms

7.2 i80-System Interface Timing Characteristics

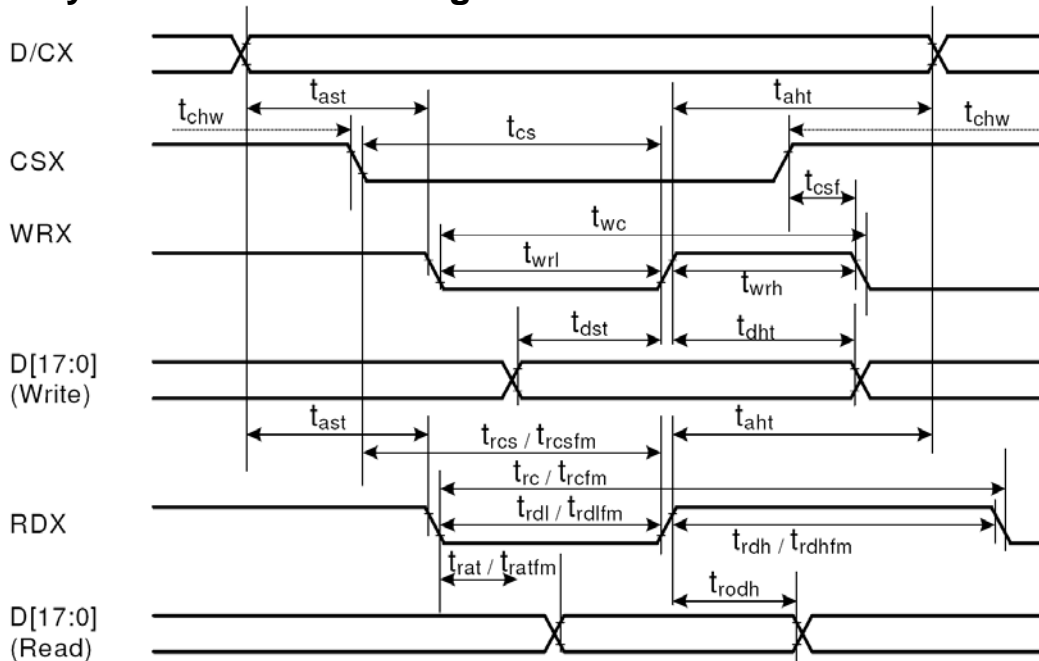

Signal	Symbol	Parameter	min	max	Unit	Description
DCX	tast	Address setup time	0	-	ns	
	taht	Address hold time (Write/Read)	0	-	ns	
CSX	tchw	CSX "H" pulse width	0	-	ns	
	tcs	Chip Select setup time (Write)	15	-	ns	
	trcs	Chip Select setup time (Read ID)	45	-	ns	
	trcfm	Chip Select setup time (Read FM)	355	-	ns	
	tcsf	Chip Select Wait time (Write/Read)	10	-	ns	
WRX	twc	Write cycle	66	-	ns	
	twrh	Write Control pulse H duration	15	-	ns	
	twrl	Write Control pulse L duration	15	-	ns	
RDX (FM)	trcfm	Read Cycle (FM)	450	-	ns	
	trdhfm	Read Control H duration (FM)	90	-	ns	
	trdlfm	Read Control L duration (FM)	355	-	ns	
RDX (ID)	trc	Read cycle (ID)	160	-	ns	
	trdh	Read Control pulse H duration	90	-	ns	
	trdl	Read Control pulse L duration	45	-	ns	
D[17:0], D[17:10]&D[8:1], D[17:10], D[17:9]	tdst	Write data setup time	10	-	ns	For maximum CL=30pF For minimum CL=8pF
	tdht	Write data hold time	10	-	ns	
	trat	Read access time	-	40	ns	
	tratfm	Read access time	-	340	ns	
	trodh	Read output disable time	20	80	ns	

7.3 3-line SPI Timing Characteristics

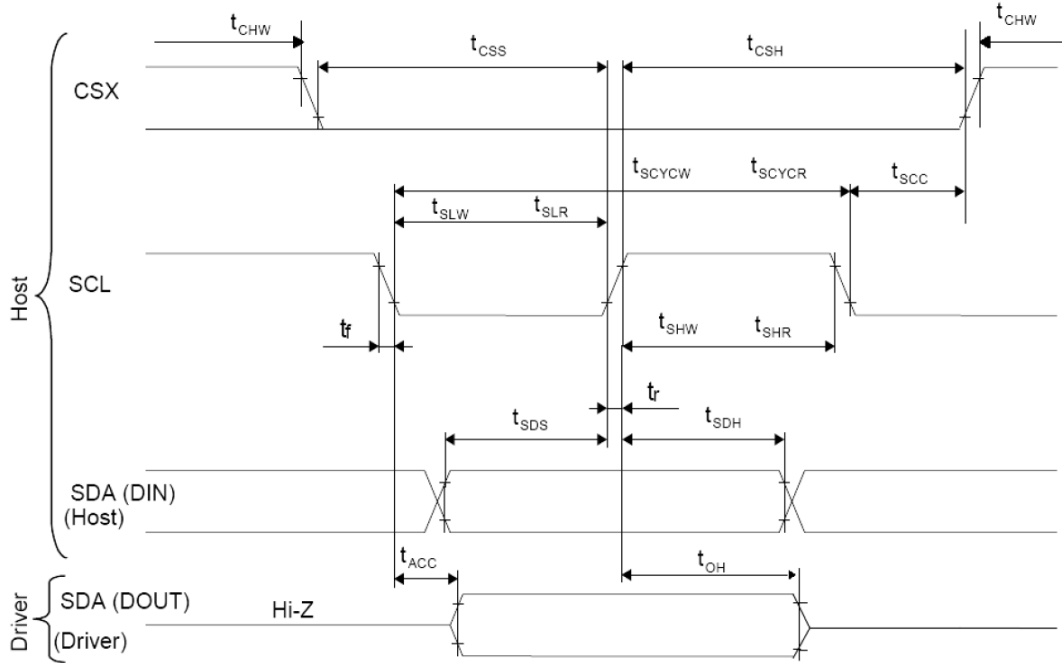

Signal	Symbol	Parameter	min	max	Unit	Description
SCL	t_{scycw}	Serial Clock Cycle (Write)	100	-	ns	
	t_{shw}	SCL "H" Pulse Width (Write)	40	-	ns	
	t_{slw}	SCL "L" Pulse Width (Write)	40	-	ns	
	t_{scycr}	Serial Clock Cycle (Read)	150	-	ns	
	t_{shr}	SCL "H" Pulse Width (Read)	60	-	ns	
	t_{slr}	SCL "L" Pulse Width (Read)	60	-	ns	
SDA / SDI (Input)	t_{sds}	Data setup time (Write)	30	-	ns	
	t_{sdh}	Data hold time (Write)	30	-	ns	
SDA / SDO (Output)	t_{acc}	Access time (Read)	10	-	ns	
	t_{oh}	Output disable time (Read)	10	50	ns	
CSX	t_{scc}	SCL-CSX	20	-	ns	
	t_{chw}	CSX "H" Pulse Width	40	-	ns	
	t_{css}	CSX-SCL Time	60	-	ns	
	t_{csh}		65	-	ns	

7.4 4-line SPI Timing Characteristics

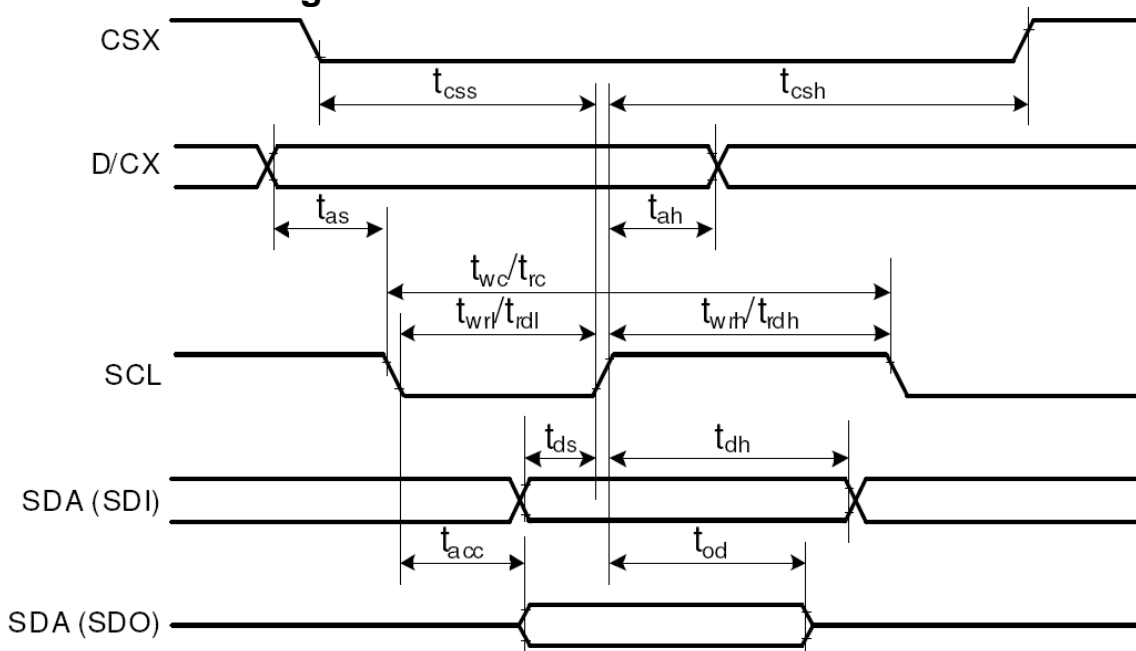

Signal	Symbol	Parameter	min	max	Unit	Description
CSX	tc _{ss}	Chip select time (Write)	40	-	ns	
	tc _{sh}	Chip select hold time (Read)	40	-	ns	
SCL	tw _c	Serial clock cycle (Write)	100	-	ns	
	tw _{rh}	SCL "H" pulse width (Write)	40	-	ns	
	tw _{rl}	SCL "L" pulse width (Write)	40	-	ns	
	tr _c	Serial clock cycle (Read)	150	-	ns	
	tr _{dh}	SCL "H" pulse width (Read)	60	-	ns	
	tr _{dl}	SCL "L" pulse width (Read)	60	-	ns	
D/CX	ta _s	D/CX setup time	10	-		
	ta _h	D/CX hold time (Write / Read)	10	-		
SDA / SDI (Input)	td _s	Data setup time (Write)	30	-	ns	
	td _h	Data hold time (Write)	30	-	ns	
SDA / SDO (Output)	tacc	Access time (Read)	10	-	ns	For maximum CL=30pF
	tod	Output disable time (Read)	10	50	ns	For minimum CL=8pF

7.5 Parallel 18/16/6-bit RGB Interface Timing Characteristics

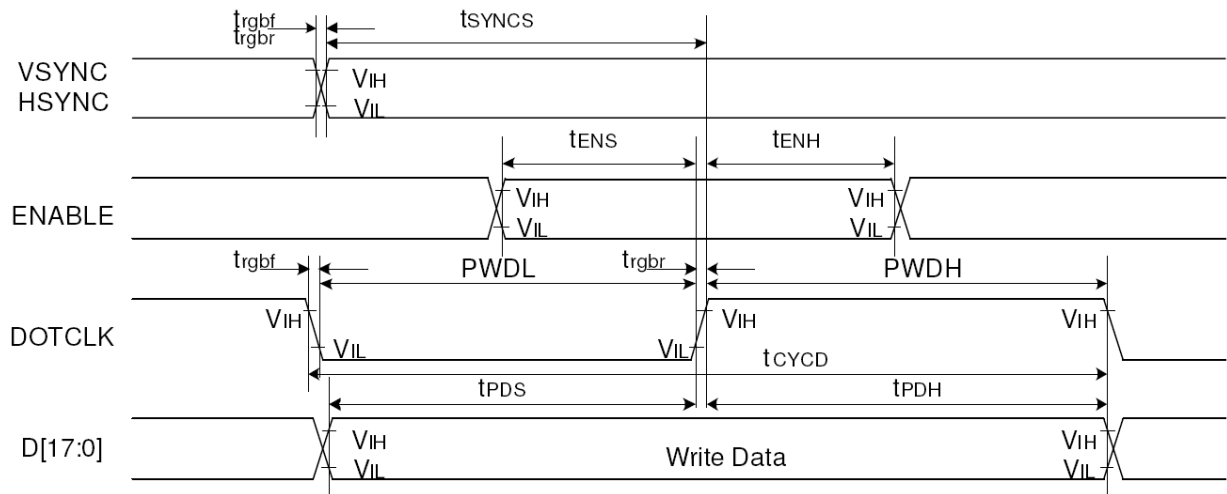

Signal	Symbol	Parameter	min	max	Unit	Description
VSYNC / HSYNC	t _{SYNCS}	VSYNC/HSYNC setup time	15	-	ns	18/16-bit bus RGB interface mode
	t _{SYNCH}	VSYNC/HSYNC hold time	15	-	ns	
DE	t _{ENS}	DE setup time	15	-	ns	
	t _{ENH}	DE hold time	15	-	ns	
D[17:0]	t _{POS}	Data setup time	15	-	ns	
	t _{PDH}	Data hold time	15	-	ns	
DOTCLK	PWDH	DOTCLK high-level period	15	-	ns	
	PDDL	DOTCLK low-level period	15	-	ns	
	t _{CYCD}	DOTCLK cycle time	100	-	ns	
	t _{rgbr} , t _{rgbf}	DOTCLK,HSYNC,VSYNC rise/fall time	-	15	ns	
VSYNC / HSYNC	t _{SYNCS}	VSYNC/HSYNC setup time	15	-	ns	6-bit bus RGB interface mode
	t _{SYNCH}	VSYNC/HSYNC hold time	15	-	ns	
DE	t _{ENS}	DE setup time	15	-	ns	
	t _{ENH}	DE hold time	15	-	ns	
D[17:0]	t _{POS}	Data setup time	15	-	ns	
	t _{PDH}	Data hold time	15	-	ns	
DOTCLK	PWDH	DOTCLK high-level pulse period	15	-	ns	
	PDDL	DOTCLK low-level pulse period	15	-	ns	
	t _{CYCD}	DOTCLK cycle time	100	-	ns	
	t _{rgbr} , t _{rgbf}	DOTCLK,HSYNC,VSYNC rise/fall time	-	15	ns	

8. Backlight Characteristics

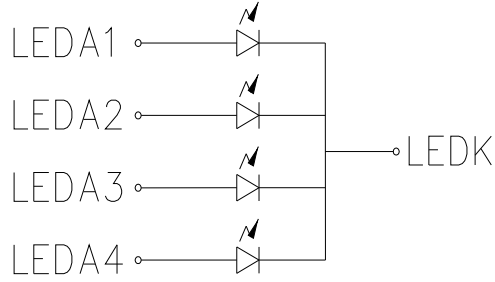

Item	Symbol	MIN	TYP	MAX	UNIT	Test Condition
Supply Voltage	V _f	2.9	3.2	3.5	V	I _f =60mA
Supply Current	I _f	-	60	80	mA	-
Luminous Intensity for LCM	-	180	230	-	Cd/m ²	I _f =60mA
Uniformity for LCM	-	80	-	-	%	I _f =60mA
Life Time	-	20000	-	-	Hr	I _f =60mA
Backlight Color	White					

9. Optical Characteristics

Item	Symbol	Condition	Min.	Typ.	Max.	Unit	Note
Transmittance (without Polarizer)	T(%)	—	—	(14.4)	—	—	
Contrast Ratio	CR	θ=0	400	500	—	—	(1)(2)
Response time	Rising	T _R	—	4	8	msec	(1)(3)
	Falling	T _F	—	12	24		
Color gamut	S(%)			60		%	
Color chromaticity (CIE1931)	White	W _x		0.283	0.303	0.323	(1)(4) CF glass (C-light)
		W _y		0.305	0.325	0.345	
	Red	R _x		0.606	0.626	0.646	
		R _y		0.314	0.334	0.354	
	Green	G _x		0.257	0.277	0.297	
		G _y		0.529	0.549	0.569	
Blue	B _x		0.122	0.142	0.162		
	B _y		0.102	0.122	0.142		
Viewing angle	Hor.	θ _L	CR>10	35	45	—	
		θ _R		35	45	—	
	Ver.	θ _U		35	45	—	
		θ _D		10	20	—	
Optima View Direction	12 O'clock						(5)

Measuring Condition:

Dark room, $25\pm 2^{\circ}\text{C}$, 15min. warm-up time.

Measuring Equipment

FPM520 of Westar Display technologies, INC., which utilized SR-3 for Chromaticity and BM-5A for other optical characteristics.

Note (1) Definition of Viewing Angle :

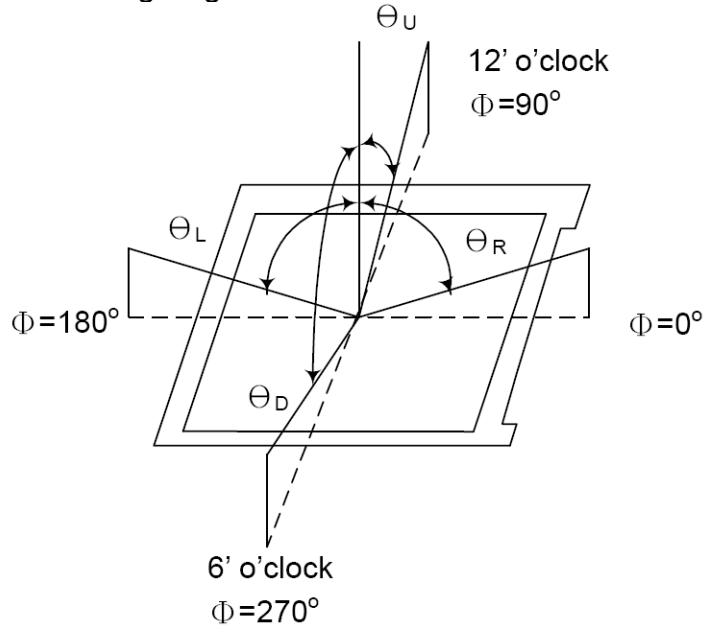

Note (2) Definition of Contrast Ratio(CR) :

Measured at the center point of panel

$$\text{CR} = \text{Luminance with all pixels white} / \text{Luminance with all pixels black}$$

Note (3) Definition of Response Time : Sum of TR and TF

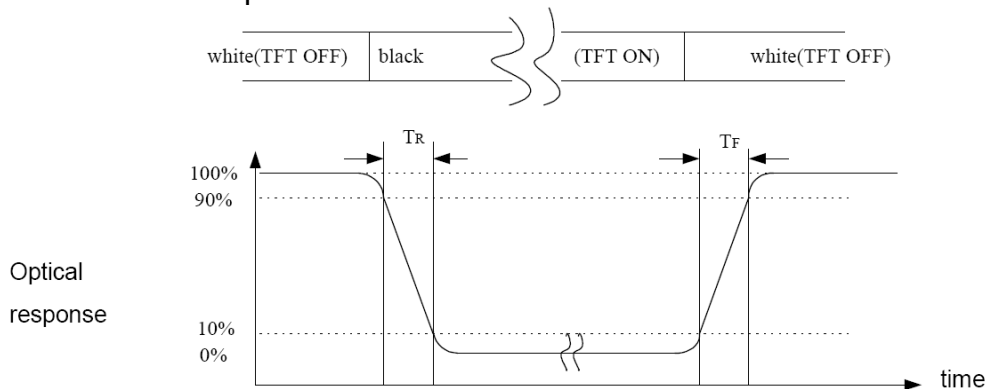

Note (4) Definition of optical measurement setup

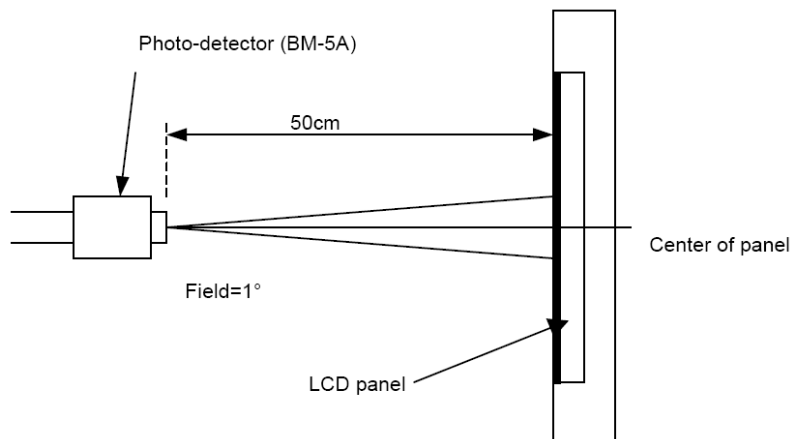

10. Reliability Test Conditions And Methods

NO.	TEST ITEMS	TEST CONDITION	INSPECTION AFTER TEST
①	High Temperature Storage	80°C±2°C×200Hours	Inspection after 2~4hours storage at room temperature,the samples should be free from defects: 1,Air bubble in the LCD. 2,Sealleak. 3,Non-display. 4,Missing segments. 5,Glass crack. 6,Current IDD is twice higher than initial value. 7,The surface shall be free from damage. 8,The electric charateristic requirements shall be satisfied.
②	Low Temperature Storage	-30°C±2°C×200Hours	
③	High Temperature Operating	70°C±2°C×120Hours	
④	Low Temperature Operating	-20°C±2°C×120Hours	
⑤	Temperature Cycle(Storage)	-20°C ↔ 25°C ↔ 70°C (30min) ← (5min) → (30min) 1cycle Total 10cycle	
⑥	Damp Proof Test (Storage)	50°C±5°C×90%RH×120Hours	
⑦	Vibration Test	Frequency:10Hz~55Hz~10Hz Amplitude:1.5M X,Y,Z direction for total 3hours (Packing Condition)	
⑧	Drooping Test	Drop to the ground from 1M height one time every side of carton. (Packing Condition)	
⑨	ESD Test	Voltage:±8KV,R:330Ω,C:150PF,Air Mode,10times	

REMARK:

- 1,The Test samples should be applied to only one test item.
- 2,Sample side for each test item is 5~10pcs.
- 3,For Damp Proof Test,Pure water(Resistance > 10MΩ)should be used.
- 4,In case of malfunction defect caused by ESD damage,if it would be recovered to normal state after resetting,it would be judge as a good part.
- 5,EL evaluation should be excepted from reliability test with humidity and temperature:Some defects such as black spot/blemish can happen by natural chemical reaction with humidity and Fluorescence EL has.
- 6,Failure Judgment Criterion:Basic Specification Electrical Characteristic,Mechanical Characteristic,Optical Characteristic.

11. Inspection Standard

This standard apply to C-STN/TFT module

1. Spot check plan:

According to spot check level II ,MIL-STD-105D Level II ,the rank of accept or reject is below:

3A 级、2A 级 : major non-conformance : AQL 0.25 minor non-conformance : AQL 0.4

A 级 : major non-conformance : AQL 0.65 minor non-conformance : AQL 1.

2. Inspection condition:

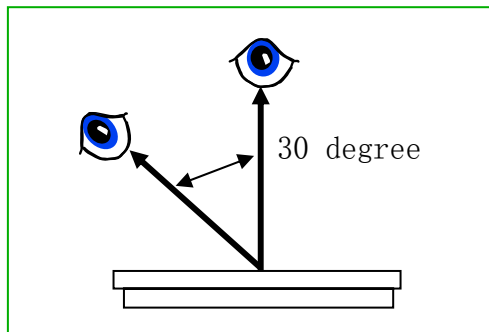

Under daylight lamp 20~40W, product distance inspector'eye 30cm,incline degree 30°.

3. LCD area define:

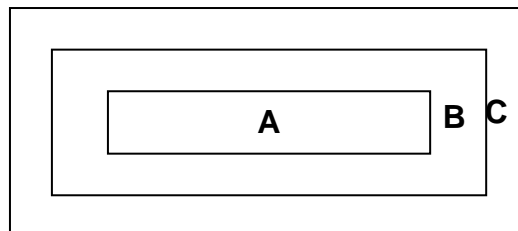

Area A: display area

Area B: VA area

Area C: out of VA area,not in sight after assembly

Remark :non-conformance at area C,but is OK that isn't influence raliability of product & assembly by customer.

4. Inspection standard

4.1 Major non-conformance

NO.	Item	Inspection standard	Rate
4.1.1	Function non-conformance	1) No display, display abnormaly 2) Miss line, short 3) B/L no function or function abnormaly 4) TP no function	major
4.1.2	miss	No matter miss what component	
4.1.3	Out of size	Module dimension out of spec	

4.2 Appearance non-conformance

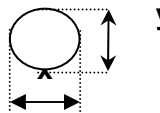
NO.	Item	Inspection standard	Rate																														
4.2.1	Black or white spot (power on)	dot non-conformance define Φ $\Phi = \frac{(x+y)}{2}$ 	Minor																														
		A grade <table border="1"> <thead> <tr> <th rowspan="2">area size (mm)</th> <th colspan="3">Most approve q'ty</th> </tr> <tr> <th>A</th> <th>B</th> <th>C</th> </tr> </thead> <tbody> <tr> <td>$\Phi \leq 0.10$</td> <td colspan="3">ignore</td> </tr> <tr> <td>$0.10 < \Phi \leq 0.15$</td> <td colspan="3">3</td> </tr> <tr> <td>$0.15 < \Phi \leq 0.20$</td> <td colspan="3">2</td> </tr> <tr> <td>$0.20 < \Phi \leq 0.25$</td> <td colspan="3">1</td> </tr> <tr> <td>$0.25 < \Phi$</td> <td colspan="3">0</td> </tr> </tbody> </table> <p>Most approve 4 damages, dot to dot $\geq 10\text{mm}$</p>		area size (mm)	Most approve q'ty			A	B	C	$\Phi \leq 0.10$	ignore			$0.10 < \Phi \leq 0.15$	3			$0.15 < \Phi \leq 0.20$	2			$0.20 < \Phi \leq 0.25$	1			$0.25 < \Phi$	0					
area size (mm)	Most approve q'ty																																
	A	B	C																														
$\Phi \leq 0.10$	ignore																																
$0.10 < \Phi \leq 0.15$	3																																
$0.15 < \Phi \leq 0.20$	2																																
$0.20 < \Phi \leq 0.25$	1																																
$0.25 < \Phi$	0																																
4.2.2	Black or white line (power on)	A grade <table border="1"> <thead> <tr> <th colspan="2">Size(mm)</th> <th colspan="3">Most approve q'ty</th> </tr> <tr> <th>L(length)</th> <th>W(width)</th> <th>A</th> <th>B</th> <th>C</th> </tr> </thead> <tbody> <tr> <td>ignore</td> <td>$W \leq 0.03$</td> <td colspan="3">ignore</td> </tr> <tr> <td>$L \leq 5.0$</td> <td>$0.03 < W \leq 0.05$</td> <td colspan="3">2</td> </tr> <tr> <td>$L \leq 3.0$</td> <td>$0.05 < W \leq 0.07$</td> <td colspan="3">1</td> </tr> <tr> <td></td> <td>$0.07 < W$</td> <td colspan="3">Treat with dot non-conformance</td> </tr> </tbody> </table> <p>Most approve 3 damages, line to line $\geq 10\text{mm}$</p>	Size(mm)		Most approve q'ty			L(length)	W(width)	A	B	C	ignore	$W \leq 0.03$	ignore			$L \leq 5.0$	$0.03 < W \leq 0.05$	2			$L \leq 3.0$	$0.05 < W \leq 0.07$	1				$0.07 < W$	Treat with dot non-conformance			Minor
Size(mm)		Most approve q'ty																															
L(length)	W(width)	A	B	C																													
ignore	$W \leq 0.03$	ignore																															
$L \leq 5.0$	$0.03 < W \leq 0.05$	2																															
$L \leq 3.0$	$0.05 < W \leq 0.07$	1																															
	$0.07 < W$	Treat with dot non-conformance																															

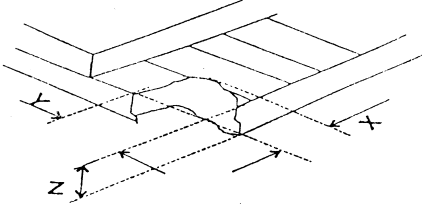
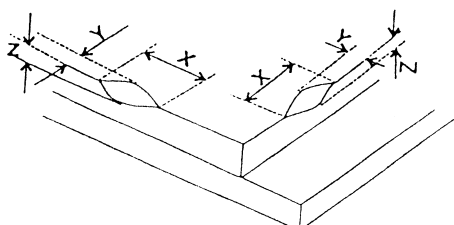
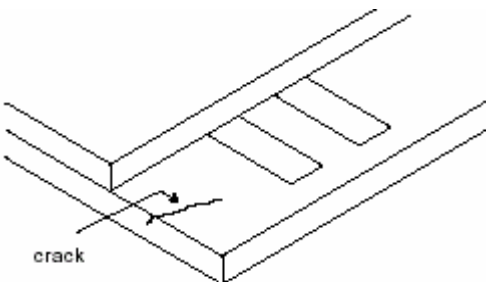
4.2.3	Polarizer position	1) polarizer attach meet drawing, disallow out of LCD. 2) polarizer must cover display area (special require unless)	Minor													
4.2.4	LCD non-conformance	<p>(i) crash at side (remark: S=ITO length)</p>  <table border="1" data-bbox="557 546 1192 642"> <thead> <tr> <th>X</th> <th>Y</th> <th>Z</th> </tr> </thead> <tbody> <tr> <td>≤3.0</td> <td>≤S</td> <td>ignore</td> </tr> </tbody> </table> <p>Crash disallow extend to ITO or seal.</p> <p>(ii) commonly surface scathe</p>  <table border="1" data-bbox="534 981 1214 1077"> <thead> <tr> <th>X</th> <th>Y</th> <th>Z</th> </tr> </thead> <tbody> <tr> <td>≤2.0</td> <td><frame edge</td> <td>ignore</td> </tr> </tbody> </table> <p>(iii) crack Disallow extend crack</p> 	X	Y	Z	≤3.0	≤S	ignore	X	Y	Z	≤2.0	<frame edge	ignore	Minor	
X	Y	Z														
≤3.0	≤S	ignore														
X	Y	Z														
≤2.0	<frame edge	ignore														
4.2.5	Contrast voltage warp	VOP/Vlcd voltage of confirmed sample ±0.15V	Minor													
4.2.6	color	Color & luminance of module scope reference spec	Minor													
4.2.7	Cross talk	Reference confirmed limit sample	Minor													

12. Handling Precautions

12.1 Mounting method

The LCD panel of SC LCD module consists of two thin glass plates with polarizes which easily be damaged. And since the module is so constructed as to be fixed by utilizing fitting holes in the printed circuit board.

Extreme care should be needed when handling the LCD modules.

12.2 Caution of LCD handling and cleaning

When cleaning the display surface, Use soft cloth with solvent [recommended below] and wipe lightly

- Isopropyl alcohol
- Ethyl alcohol

Do not wipe the display surface with dry or hard materials that will damage the polarizer surface.

Do not use the following solvent:

- Water
- Aromatics

Do not wipe ITO pad area with the dry or hard materials that will damage the ITO patterns

Do not use the following solvent on the pad or prevent it from being contaminated:

- Soldering flux
- Chlorine (Cl) , Sulfur (S)

If goods were sent without being silicon coated on the pad, ITO patterns could be damaged due to the corrosion as time goes on.

If ITO corrosion happens by miss-handling or using some materials such as Chlorine (Cl), Sulfur (S) from customer, Responsibility is on customer.

12.3 Caution against static charge

The LCD module uses C-MOS LSI drivers, so we recommend that you:

Connect any unused input terminal to Vdd or Vss, do not input any signals before power is turned on, and ground your body, work/assembly areas, assembly equipment to protect against static electricity.

12.4 packing

- Module employs LCD elements and must be treated as such.
- Avoid intense shock and falls from a height.
- To prevent modules from degradation, do not operate or store them exposed directly to sunshine or high temperature/humidity

12.5 Caution for operation

- It is an indispensable condition to drive LCD's within the specified voltage limit since the higher voltage than the limit causes the shorter LCD life.
- An electrochemical reaction due to direct current causes LCD's undesirable deterioration, so that the use of direct current drive should be avoided.
- Response time will be extremely delayed at lower temperature than the operating temperature range and on the other hand at higher temperature LCD's show dark color in them. However those phenomena do not mean malfunction or out of order with LCD's, which will come back in the specified operation temperature.
- If the display area is pushed hard during operation, some font will be abnormally displayed but it resumes normal condition after turning off once.
- A slight dew depositing on terminals is a cause for electro-chemical reaction resulting in terminal open circuit.

Usage under the maximum operating temperature, 50%Rh or less is required.

12.6 storage

In the case of storing for a long period of time for instance, for years for the purpose of replacement use, the following ways are recommended.

- Storage in a polyethylene bag with the opening sealed so as not to enter fresh air outside in it. And with no desiccant.
- Placing in a dark place where neither exposure to direct sunlight nor light's keeping the storage temperature range.

- Storing with no touch on polarizer surface by the anything else.
[It is recommended to store them as they have been contained in the inner container at the time of delivery from us

12.7 Safety

- It is recommendable to crash damaged or unnecessary LCD's into pieces and wash off liquid crystal by either of solvents such as acetone and ethanol, which should be burned up later.
- When any liquid leaked out of a damaged glass cell comes in contact with your hands, please wash it off well with soap and water

13. Precaution For Use

13.1

A limit sample should be provided by the both parties on an occasion when the both parties agreed its necessity. Judgment by a limit sample shall take effect after the limit sample has been established and confirmed by the both parties.

13.2

On the following occasions, the handing of problem should be decided through discussion and agreement between responsible of the both parties.

- When a question is arisen in this specification
- When a new problem is arisen which is not specified in this specifications
- When an inspection specifications change or operating condition change in customer is reported to GT LCD , and some problem is arisen in this specification due to the change
- When a new problem is arisen at the customer's operating set for sample evaluation in the customer site.

14. Packing Method

